



Analogue meter using stepping motor technology

- Non sensitive against shock and vibration
- Operation in any installed position
- Accuracy class 0,5
- Scale- and pointer LED illumination
- For vehicles and ship applications

Technical data

Supply voltage:	18 ... 36 V DC	
Power consumption:	< 1,5 VA	
Starting current:	1 A about 1 sec.	
<u>Electrical security</u>		
Overvoltage category:	CAT III	EN 61010-1:2001
Working voltage:	50 V	EN 61010-1:2001
Protection class:	IP 56 Front housing panel protection	EN 60529
	IP 20 Rear panel protection	EN 60529
Electromagnetic compatibility	EMC Standart 89/336 EWG/EEC EN 61326:2004	
Shock level:	30g	DIN EN 60 051
Vibration level:	5,0g	DIN EN 60 051
<u>Range of application (Climatic demands):</u>		
Humidity:	≤75% (at 21°C) annualmean ≤ 95% (at 25°C) 30 days per year ≤ 85% (at 23°C) remaining days	
Operating temperature:	-25°C ... +55°C	
Storage temperature:	-25°C ... +55°C	
<u>Electrical characteristic values</u>		
Input:	4 - 20mA	
Input resistance:	about 100 Ohm	
Illumination:	LED, 24V DC with dimmer for scale and pointer	
Stepping motor:	Gear motor, with resolution of 0,083° (4320 step)	
Rotation speed:	max. 1,5sec./360°	
Accuracy:	class 0,5	
Linearity failure:	± 1°	
<u>Housing</u>		
Material:	Steel plate, hot - dip galvanized	
Frontframe:	Polycarbonat, black (flammability class UL94 V -0)	
Window:	Antireflectiv silcate glass	
Mounting position:	anyone	
Weight:	420 g	
Mounting fasteners:	Screw clamp	
Scale design:	to be made to customer's specification	
Option:	Pointer position reflection at 180° by closing a -free of potential-contact	

Dimensional Drawing:

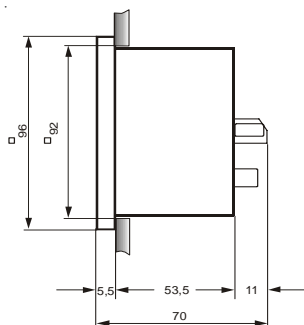

Specials:

Calibration will be done ex works. Customer specific calibration is possible by using USB interface. Calibration of Zero point, initial value and final value made by customer using the calibration software.

Connections:

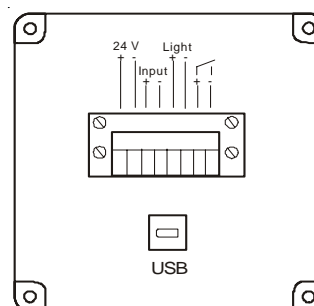

db_rsa_gb.pmd 08.07 subject to change without notice