

USER`S MANUAL



metrix
electronics

Metrix Electronics Limited

Precision Enterprise House, Rankine Road, Daneshill, BASINGSTOKE, RG24 8PP, U.K.

Tel: +44 (0)1256 864150, Fax: +44 (0)1256 864154

E-mail: sales@metrix-electronics.com, Web: www.metrix-electronics.com

Multi - Display Device
MA 400 AM

Safety instructions (EN 61010-1)

In order to preclude any danger to the operator, the following instructions should be followed:

- a) In case any damage or malfunction is detected, take the unit out of operation without delay.
- b) Before disassembling the unit, disconnect all inputs / outputs and the supply voltage. When mounting the unit and the connections, make sure all live components are protected from being touched directly.
- c) Comply with the usual regulations and safety provisions for low and high current systems, in particular country-specific safety provisions.
- d) The maximum admissible potential existing between the pin groups as well as to the external protective conductor must not be exceeded.
- e) Make sure that the unit is properly mounted before connection and power on !

In order to preclude any damage to the unit, the following items must be taken into account:

The maximum admissible potential between the pin groups must not be exceeded.
This applies in particular to high voltage tests.



Refer to the instruction manual !



Warning: Hazardous live voltage !

WARNING:

There is always hazardous voltage present in certain parts during the operation of electrical equipment. Non-observance of the safety instructions can result in severe personal injury or damage to property. Only qualified personnel should work on this equipment. The successful and safe operation of this equipment is dependant on proper transport, storage, set-up, installation and careful operation and maintenance.

QUALIFIED PERSONNEL

Are personnel who are familiar with the set-up, installation, commissioning and operation of the product and have the qualifications corresponding to their activities, e.g.:

- Are trained and authorised to energise, de-energise, clear, ground and tag circuits and equipment / systems in accordance with established safety standards.
- Are trained in the proper care and use of protective equipment in accordance with established safety practices.
- Are trained in first aid.

Safety according to EN 61010-1, VDE 0411

CAT III 300 V

Pollution degree : 2; indoor use; altitude <2000 m; relative humidity <80 % up to 31 °C;
Temperature: 5 °C to 40 °C;

Contents	Side
1. General description, technical hints	2
2. Principle of operation	2
3. Maintenance hints	3
4. Installation of MA 400 AM	3
5. Auxilliary energie	3
6. Voltage measurement	4
7. Current measurement	4
8. Connection variants	4
9. Example connections	5
10. Commissioning	6
11. Operation of the unit	6
11.1 Character set of LC display	6
11.2 Configuration possibilities	8
11.3 Programming sequence	9
11.3.1 Measurement menu	9
11.3.2 Menu selection	9
11.3.3 Selecting the display windows	10
11.3.4 Setting the transformer ratios	10
11.3.5 Setting numerical values	11
11.3.6 Resetting maximum values, bimetal functions, energy meters ans operating hour meters	11
11.3.7 Status windows	11
12. Overview of display screens	12
13. Energy measurement with impulse measurement	21
13.1 Entering the pulse duration	22
13.2 Entering the pulse value	22
14. Technical data	23
14.1 Inputs	23
14.2 Display ranges and measuring errors	24
14.3 Setting value	25
14.4 Operating conditions	25

Three-Phase Measuring Instrument MA400 AM

1. General description, technical hints

The three-phase measuring instrument MA400 AM is designed for the measurement of currents and voltages as well as other parameters in three-phase systems with neutral conductor (N conductor) of low-voltage installations. In addition to the values of currents and voltages, the instrument allows users to indicate numerically determined values for such parameters as effective power, reactive power, apparent power, frequency and power factor. Moreover, a number of further functions are implemented, including averaging over selectable time intervals and the display of selected maximum and minimum values.

Measurement voltages of 400 V_{L-L} in the frequency range of 50 Hz and 60 Hz (48 ... 52 Hz and 58 ... 62 Hz, respectively) can be directly connected. Other measurement values are available as an option (to be specifically ordered). Higher voltages can be connected only via suitably interconnected voltage transformers. The measurement voltages must be connected via suitable disconnecting devices and via overcurrent protective devices.

Measurement currents of 5 A can be connected directly to the measuring instrument, taking into consideration the permissible voltages to earth, while higher currents may be connected via appropriate current transformers. Normally, the instrument should generally be used with current transformers. Unloaded current transformers may involve the risk of shock. The three-phase measuring instrument is accommodated in a DIN panel-type enclosure with a front measuring 96 x 96 mm². The unit is connected to the measurement voltages and currents via clamp connections on the rear of the unit.

The unit may be connected exclusively by trained and properly qualified personnel (authorised personnel), taking into account the relevant general and, if applicable, special safety regulations.

2. Principle of operation

The three-phase measuring instrument MA400 AM is designed to electronically measure currents and voltages in a three-phase system with N conductor. If there is no N conductor, it will have to be created in a suitable manner, for example, via three voltage transformers.

The envisaged mains frequency is in the range from 48 Hz to 52 Hz. The current and voltage values are digitalized and processed in a suitable manner so that the respective effective value is available in a digital form.

It has to be ensured that currents and voltages are continuously present. It is, for example, not possible to carry out measurements on packet-control type devices or the like.

The auxiliary energy for operating the MA400 AM is formed from the three voltages L1-N, L2-N and L3-N. It must be ensured that all three voltages are available.

From the current and voltage values which have been measured and digitalized, all other values in the three-phase system are calculated by an internal processor and made available for further processing. The processor determines the respective numeric values as well as the appropriate unit of measurement to be displayed.

The MA400 AM is exclusively designed as a display device and, thus, does not have any further terminals, for example, for derived output variables or for pulse outputs or limit value outputs.

3. Maintenance hints

The MA 400 AM is designed for maintenance-free operation and, thus, is a sealed device with the corresponding marking. Parameterisations are all performed via keys, so that it will not be necessary to open the unit. The seal also serves as proof that the relevant safety related tests of the unit have been completed. Consequently, it must neither be removed nor damaged. Only the manufacturer or authorised workshops are allowed to open the unit for performing repairs or the like.

Similarly, any readjustment required may also be carried out only at the manufacturer's shop.

4. Installation of MA 400 AM

The MA 400 AM is intended for permanent installation in low-voltage systems. If it is to be used in a medium-voltage system, the operator will have to take appropriate measurement and safety related measures.

5. Auxiliary energy

The auxiliary energy is obtained from the voltages L1-N, L2-N and L3-N. Thus, these three voltages are required for operating the unit. Various power supply units for the different voltages are provided in the unit. The unit does not contain a wide-range power supply unit.

9. Example connections

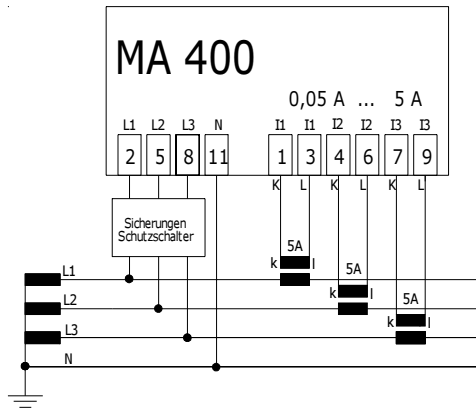

Figure 2 Four-conductor three-phase system, measurement with three external current transformers; the three voltages L1, L2 and L3 are directly connected to the MA 400 AM via safety devices (fuses, disconnecting switches).

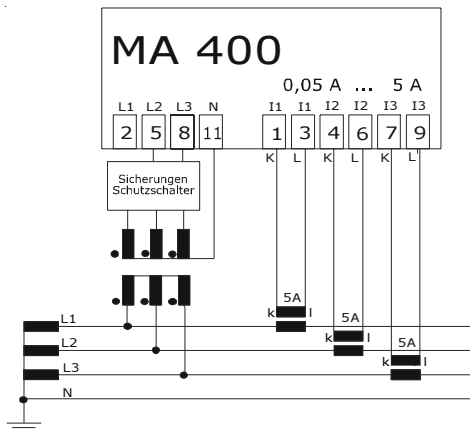

Figure 3 Three-conductor three-phase system, measurement with three external current transformers; the three voltages L1, L2 and L3 are connected to the MA 400 AM via voltage transformer and via safety devices (fuses, disconnecting switches).

10. Commissioning

Before connecting the MA400 AM, check all voltages and make sure that they conform to the specifications of the unit (nameplate). Then connect the respective leads for the current and voltage measurement inputs, observing the specified order. It should be noted once again that all three voltages are required for operating the MA400 AM.

11. Operation of the unit

A 3-digit numerical display (LCD) with 3 lines each and further symbols is used for displaying, with the 3-digit numerical displays being designed for displaying the measuring values.

11.1 Character set of LC display

The display has a three-line digital display with three digits each. Decimal points can be displayed after the first and after the second digit. The measuring instrument MA 400 AM itself sets the decimal point. The smallest number which can be displayed is – 999, the largest one 999. All values within this numerical range are determined by the internal processor and displayed.

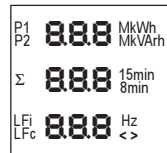

Apart from the numbers with decimal points, there is a number of special characters. The display of the special characters is controlled by the processor. The user may neither influence the characters as such nor control them.

The layout of the screens determines which, when and for which measuring task special characters are displayed. This will be discussed in greater detail in the section "Screens" in which the various screens are shown. In some cases, combinations may be required for displaying certain measuring values, e.g., V for the voltage, Hz for indicating the mains frequency.

Special character Σ

The special character Σ shows that the total values of the three-phase system are indicated. This applies to measurements of the total powers, energy and power factor.

Special character LFi

This special character is displayed when an inductive phase shift occurs.
The display is in $\cos f$.

Special character LFc

This special character is displayed when a capacitive phase shift occurs.
The display is on $\cos f$.

Special character MkWh

All characters of this character combination are activated by the processor based on the selected screen.

The character M stands for mega
the character k for kilo
the character W for watt
and character h for hour.

Thus, it is possible, e.g., to form and display the character combination kWh for kilowatt-hour.

Special character MkVArh

All characters of this character combination are activated by the processor based on the selected screen.

The character M stands for mega
the character k for kilo
the character V for volt
the character A for ampere
the character r for reactive
and character h for hour.

Thus, it is possible, e.g., to form and display the character combination VAr for reactive power.

Special characters 15min and 8min

Display of a mean value function

Special character Hz

Display of mains frequency

Special character < >

Display of minim value (<) or maximum value (>)

Special character P1

The character P1 shows that the user is in the selection menu for the display windows.

Special karakter P2

This character shows that the user is in the selection menu for the current transformers, voltage transformers, pulse time and pulse weight.

The units are operated by two keys with the following functions:

ENTER key - ↵	Acknowledge an entry or select a parameterization menu
MODE key - →	Scrolling or change function
Both keys simultaneously → + ↵	Store or delete

The various meanings are explained below.

11.2 Configuration possibilities

Current transformer ratio:

A maximum transformer ratio of 999 kA relative to the factory-set secondary current (5 or 1 A) can be set. The secondary current cannot be changed.

**Factory setting: transformer ratio of 1 : 1
(primary current = secondary current)**

Voltage transformer ratio:

A maximum transformer ratio of 999 kV relative to the factory-set secondary voltage can be set. The secondary voltage can be changed within the specified limits.

**Factory setting: transformer ratio of 1 : 1
(primary voltage = secondary voltage)**

Pulse length

The length of the pulses for the two outputs for active energy and reactive energy can be set in a range from 0,05 s to 2,00 s. the setting applies to both aoutputs. Settings below 0,05 s and above 2,00 s are prevented by the software.

Factory setting: 0,05 s

Pulse weight for active energy and reactive energy:

A weight of 0 Wh ... 999 kWh and 0 Varh... 999 kVarh, respectively, can be assigned to an output pulse.

A weight of 0 Wh and 0 Varh, respectively, means that the output concerned is not active.

Factory setting: 0.00 Wh and 0.00 Varh.

Password:

The settings described above can be protected by a password in the range from 01 ... 99. If the password is 00, no password check will be made when the configuration values are changed.

Assigning a password **is not mandatory**.

Factory setting: 00

11.3 Programming sequence

11.3.1 Measurement menu

On powering up the unit, the unit is in the measurement menu. In the measurement menu, the windows selected by the user are displayed. For changing between the display windows, the „→“ - key has to be pressed.

Operating the „↵“ - key invoke the selection menu.

11.3.2 Menu selection

Operating the „↵“ key will invoke the selection menu.

- P1** - Programming level 1 – selection of windows
- P2** - Programming level 2 – entry of transformer ratios for energy parameters

This level can be protected by a password.

PAS Here you can enter an appropriate password, if you want.

By operating the „→“ - key, you can select P1, P2 or PAS. A flashing P1 or P2 or P (of PAS) (here represented by the underscored letter) indicates the menu to be selected. By operating the „↵“ - key you get to the selected submenu.

Once the submenu has been carried out, you always return to the measurement menu. If no submenu is selected, pressing the „→“ and „↵“ - key simultaneously will bring you back to the measurement menu.

11.3.3 Selecting the display windows

In this setting, the windows which are of interest to the user are selected from the total number of display windows available.

In the factory, all windows are selected by default.

When you acknowledge the flashing P1 in the selection menu with the „↵“ - key, you get to the window selection screen. If the „→“ key is pressed, the window displayed will not be accepted for selection. Pressing „↵“ will accept the window. Then the next window is displayed. When the last possible window (operating hour meter) is displayed, pressing one of the keys will bring you back to the first window that has not yet been selected. Thereafter, only the windows that have not yet been selected will be displayed.

By pressing both keys „→“ + „↵“ simultaneously, you exit the selection menu and return to the normal measurement menu.

11.3.4 Setting the transformer ratios

P2 is flashing in the selection menu. When you operate the „↵“ - key and the chosen password is 00, the current transformer ratio will be displayed. If a password has been assigned, the request to enter the password appears. If a wrong password is entered, F appears on the screen. If a wrong password is entered three times, the unit is reset to the measurement mode.

By operating the „→“ - key, you can have displayed in succession the other values selected for the voltage transformer ratio, pulse length, pulse weight for the active energy, pulse weight for the reactive energy and the information window for the software version and configuration. If you wish to change the settings, you have to operate the „↵“ - key in the appropriate display window to invoke the edit mode. In this mode, P2 appears, and the unit of measurement or figure to be changed is flashing. After setting has been completed, you return to the respective display window in which the selected values are displayed.

11.3.5 Setting numerical values

In this configuration you have to enter three-digit numbers with a decimal point. To enter the desired value, proceed as follows:

The respective digit is flashing. Each time the „→“ key is operated the value shown will be increased by „1“. By pressing the „↵“ key, you get to the next digit. When all three digits have been set, you acknowledge the value by simultaneously pressing the two keys „→“ + „↵“. Then you can assign the point to the appropriate digit place by means of the „→“ key. Pressing both keys „→“ + „↵“ will terminate the setting of numerical values. As password, a two-digit number must be entered.

The respective digit is flashing. Each time the „→“ key is operated, the value shown will be increased by „1“. By pressing the „↵“ key, you get to the next digit. When all two digits have been set, you acknowledge the value by simultaneously pressing the two keys „→“ + „↵“. This will complete the setting.

If no keys are operated for more than about 1 min. in the setting menu, the respective menu will be exited, and the unit reset to the normal measurement mode.

In the flow diagrams shown below, the aforementioned settings are explained.

11.3.6 Resetting maximum values, bimetal functions, energy meters and operating hour meters

When you have selected one of the windows of the above mentioned measurement functions, you can reset the values to „0“ by simultaneously pressing the keys „→“ + „↵“.

11.3.7 Status windows

The version number indicates the current software version. 001 means software version No. 1. Improved versions of the software are consecutively numbered. The versions are downward-compatible.

001	Version
00	State 1
00	State 2

State 1 Coding of as-delivered state
1st digit voltage input

00 Standard version

0 = 400 V_{L-L}

1 = 100 V_{L-L}

2 = 690 V_{L-L}

0 = 5 A

1 = 1 A

2st digit current input

State 2 Coding of parameterisation

00 = no parameterisation

01 = customer-specific
parameterisation

12. Overview of display screens

Screen 1: Display of three phase currents: current measurement

In this screen, the three currents flowing in the three-phase system with neutral conductor are displayed. On selecting this screen, 5.00 is displayed as digit string and A as unit of measurement.

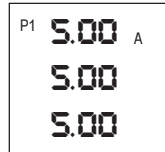

Screen 2: Display of instantaneous voltage values: voltages to neutral conductor

In this screen, the three voltages to the neutral conductor are measured and displayed. On selecting this screen, 231 is displayed as digit string and V as unit of measurement.

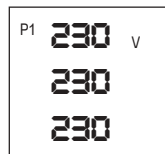

Screen 3: Display of instantaneous voltage values: voltages Lx to Lx

In this screen, the three voltages L1-L2, L2-L3 and L3-L1 are calculated by the internal processor and displayed on the display. On selecting this screen, 400 is displayed as digit string and V as unit of measurement. No special character is envisaged for distinguishing this screen from screen 2. Distinguishing between the two screens, if both have been included by the user in his menu, thus, is possible only by comparing the values with the default values which usually are known.

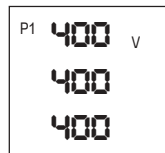

Screen 4: Display of 3 x apparent power voltages Lx to N

In this screen, the calculated instantaneous values of the apparent power are displayed. On selecting this screen, 888 is displayed as digit string and VA as unit of measurement. The voltages Lx to N are used for the calculation.

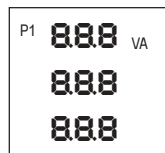

Screen 5: Display of instantaneous values; 3 x effective power; voltages Lx to N

In this screen, the calculated instantaneous values of the effective power are displayed. On selecting this screen, 888 is displayed as digit string and W as unit of measurement. The voltages Lx to N are used for the calculation.

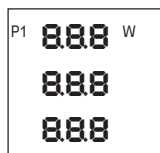

Screen 6: Display of 3 x reactive power; voltages Lx to N

In this screen, the calculated instantaneous values of the reactive power are displayed. On selecting this screen, 888 is displayed as digit string and VAR as unit of measurement. The voltages Lx to N and the three measured currents I1, I2 and I3 are used for the calculation.

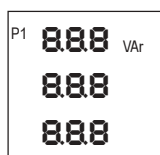

Screen 7: Display of frequency per phase

In this screen, the frequencies are displayed for each phase. On selecting this screen, 888 is displayed as digit string and Hz as unit of measurement.

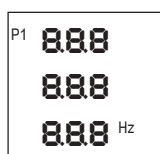

Screen 8: Display of power factor per phase

In this screen, the power factors are displayed for each phase. On selecting this screen, 888 is displayed as digit string and LFi (power factor inductive) and LFc (power factor capacitive) as unit of measurement.

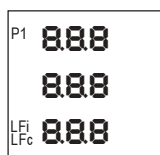

Important: In the display mode, both LFi and LFc will be displayed in all cases. The actual power factor will be determined by the sign.

Screen 9: Display of mean values; 8min current measurement

In this screen, the three currents flowing in the three-phase system are averaged over a period of 8 minutes and displayed on the display. On selecting this screen, 5.00 is displayed as digit string, A as unit of measurement as well as 8min as averaging time.

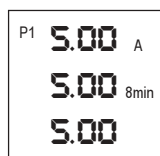

Screen 10: Display of mean values; 8min current measurement display of „non-return pointer“

In this screen, the three currents flowing in the three-phase system are averaged over a period of 8 minutes. The highest averaged value achieved up to the point of time eached is displayed on the display. On selecting this screen, 5.00 is displayed as digit string, A as unit of measurement, 8min as averaging time and > for identifying the non-return pointer.

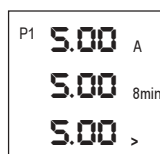

Screen 11: Display of mean values; 15min current measurement

In this screen, the three currents flowing in the three-phase system are averaged over a period of 15 minutes and displayed on the display. On selecting this screen, 5.00 is displayed as digit string, A as unit of measurement as well as 15min as averaging time.

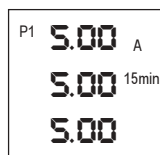

Screen 12: Display of mean values; 15min current measurement display of „non-return pointer“

In this screen, the three currents flowing in the three-phase system are averaged over a period of 15 minutes. The highest averaged value achieved up to the point of time reached is displayed on the display. On selecting this screen, 5.00 is displayed as digit string, A as unit of measurement, 15min as averaging time and > for identifying the non-return pointer.

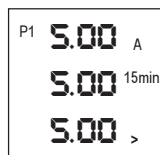

The mean value is formed based on an internally stored function. In screen 9 or 11, the mean value which is formed over the time, and the screen 10 or 12 the „non-return pointer value“ are displayed.

The non-return pointer value is the maximum value which has occurred since the start of the mean value function. The non-return pointer value is retained also after disconnection of the power supply or after a decrease in the mean value.

The function is started immediately upon activation of the screen.

If the 8min screen has been selected, it is no longer possible to change over to the 15min screen.

Deleting of displayed values (n)

The mean values of the currents and non-return pointer values are displayed on the display. To delete these values, both keys must be pressed simultaneously. Then, the value "000" will be displayed, and the averaging process or non-return pointer process starts anew.

Note that (like the analogue bimetallic indicator) the non-return pointer value can be reset only to the currently still existing mean value. Consequently, for a defined creation of a start condition, always set the mean value display to zero first.

Screen 13: Display of total apparent power; voltages Lx to N

In this screen, the calculated instantaneous values of the total apparent power are displayed. On selecting this screen, 888 is displayed as digit string, Σ and VA as unit of measurement. The voltages Lx to N are used for the calculation.

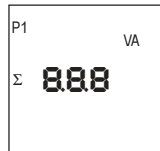

Screen 14: Display of total effective power; voltages Lx to N

In this screen, the calculated instantaneous values of the total effective power are displayed. On selecting this screen, 888 is displayed as digit string, Σ and W as unit of measurement. The voltages Lx to N are used for the calculation.

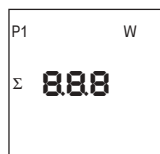

Screen 15: Display of total reactive power; voltages Lx to N

In this screen, the calculated instantaneous values of the total reactive power are displayed. On selecting this screen, 888 is displayed as digit string, Σ and VAR as unit of measurement. The voltages Lx to N are used for.

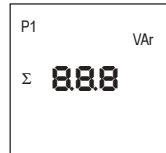

Screen 16: Display of total power factor

In this screen, the power factor is displayed. On selecting this screen, 888 is displayed as digit string, Σ and LFi (power factor inductive) and LFc (power factor capacitive) as unit of measurement. Important: In the display mode, both LFi and LFc will be displayed in all cases. The actual power factor will be determined by the sign.

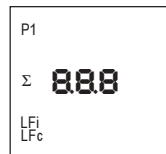

Fenster 17: Display of maximum values; 3x current

In this window, the measured maximum current values are displayed. The reading is updated only when a higher value than that shown in the display is measured. The character „>“ denotes that the value in question is a maximum value, and „A“ is the unit of measurement for the current.

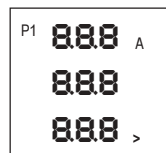

Pressing both keys simultaneously will delete the maximum memory and start the new determination of the maximum value. When the unit is switched off, the maximum values are not stored.

Screen 18: Display of maximum values; 3x voltages Lx to N

In this window, the measured maximum voltage values are displayed. The reading is updated only when a higher value than that shown in the display is measured.

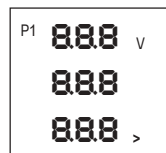

The character „>“ denotes that the value in question is a maximum value, and „V“ is the unit of measurement for the voltage.

Pressing both keys simultaneously will delete the maximum memory, and the new determination of the maximum value is started.

When the unit is switched off, the maximum values are not stored.

Screen 19: Display of maximum values: 3x apparent power

In this window, the measured maximum values for the apparent powers per phase are displayed. The reading is updated only when a higher value than that shown in the display is measured.

The character „>“ denotes that the value in question is a maximum value, and „VA“ is the unit of measurement for the apparent-power.

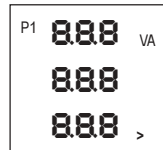

Pressing both keys simultaneously will delete the maximum memory, and the new determination of the maximum value is started.

When the unit is switched off, the maximum values are not stored.

Screen 20: Display of maximum values: 3x active power

In this window, the measured maximum values for the active powers per phase are displayed. The reading is updated only when a higher value than that shown in the display is measured.

The character „>“ denotes that the value in question is a maximum value, and „W“ is the unit of measurement for the active-power.

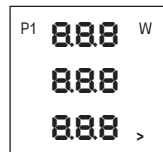

Pressing both keys simultaneously will delete the maximum memory, and the new determination of the maximum value is started.

When the unit is switched off, the maximum values are not stored.

Screen 21: Display of maximum values: 3x reactive power

In this window, the measured maximum values for the reactive powers per phase are displayed. The reading is updated only when a higher value than that shown in the display is measured.

The character „>“ denotes that the value in question is a maximum value, and „VAR“ is the unit of measurement for the reactive-power.

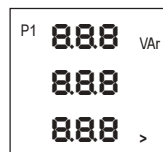

Pressing both keys simultaneously will delete the maximum memory, and the new determination of the maximum value is started.
When the unit is switched off, the maximum values are not stored.

Screen 22: Display of maximum values for the total apparent power

In this window, the measured maximum values for the total apparent power are displayed. The reading is updated only when a higher value than that shown in the display is measured.

The character „>“ denotes that the value in question is a maximum value, and „VA“ is the unit of measurement for the apparent-power.

The character „ Σ “ indicates that the value shown represents the total power.

Pressing both keys simultaneously will delete the maximum memory, and the new determination of the maximum value is started.

When the unit is switched off, the maximum values are not stored.

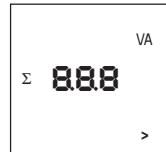

Screen 23: Display of maximum values for the total active power

In this window, the measured maximum values for the total active power are displayed. The reading is updated only when a higher value than that shown in the display is measured.

The character „>“ denotes that the value in question is a maximum value, and „W“ is the unit of measurement for the active power.

The character „ Σ “ indicates that the value shown represents the total power.

Pressing both keys simultaneously will delete the maximum memory, and the new determination of the maximum value is started.

When the unit is switched off, the maximum values are not stored.

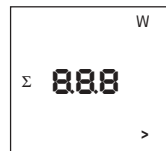

Screen 24 : Display of maximum values for the total reactive power

In this window, the measured maximum values for the total reactive power are displayed. The reading is updated only when a higher value than that shown in the display is measured.

The character „>“ denotes that the value in question is a maximum value, and „VAr“ is the unit of measurement for the active power.

The character „Σ“ indicates that the value shown represents the total power.

Pressing both keys simultaneously will delete the maximum memory, and the new determination of the maximum value is started.

When the unit is switched off, the maximum values are not stored.

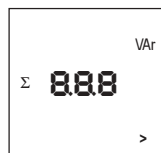

Screen 25 : Display of rotating field

In this window, the direction of the rotating field is displayed, the premise being that for the connection sequence L1->L2->L3 the direction of rotation is clockwise, and for L3-L2-L1 counterclockwise. The directions are indicated as follows:

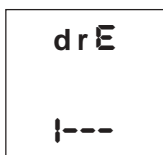

„CW“ direction of rotation

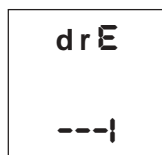

„CCW“ direction of rotation

Screen 26 : Display of active energy

Displays the active energy. All 9 digits are used to display the active energy. The total value is obtained by stringing the digits together, starting from the top left-hand side to the bottom right-hand side. The unit of measurement and the decimal point are automatically determined and displayed.

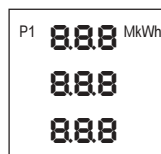

The value range shown is dependent on the selected transformer ratio:

0 ... 999 999 9.99 kWh for $WV < 10$
0 ... 999 999 99.9 kWh for $10 \geq WV < 100$
0 ... 999 999 999 kWh for $100 \geq WV$

$WV - \text{transformer ratio} = \text{product of current transformer ratio} \times \text{voltage transformer ratio}$

Important!

The active-energy meter is fitted with a reversal preventing device. Metering of the energy takes place only when electric energy is drawn.

Screen 27: Display of reactive energy

Displays reactive energy. All 9 digits are used for displaying the reactive energy. The total value is obtained by stringing the digits together, starting from the top left-hand side to the bottom right-hand side. The unit of measurement and the decimal point are automatically determined and displayed.

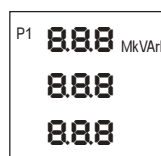

The value range shown is dependent on the selected transformer ratio:

0 ... 999 999 9.99 kVArh bei $WV < 10$
0 ... 999 999 99,9 kVArh bei $10 \geq WV < 100$
0 ... 999 999 999 kVArh bei $100 \geq WV$

$WV - \text{transformer ratio} = \text{product of current transformer ratio} \times \text{voltage transformer ratio}$

Important!

The reactive-energy meter is fitted with a reversal preventing device. Metering of the energy takes place only when an inductive load is active.

To erase the energy display (reset to zero)

The user must press both keys simultaneously. Changing, e.g., the transformer ratios will also cause resetting of the energy.

When the MA400 is connected, energy measurement will commence immediately, there is no starting condition. If the user wants to have the energy display started at a certain point of time, he must first set the display to zero.

Storage of energy value

The energy value is stored after every 15 minutes. Following switching off of the MA400 or after a power outage, the stored value will be invoked at power-up.

Screen 28: Operating hour meter

The operating hour meter is used to meter the time for which the MA400 is on, measuring and indicating the values to be measured. Readings are indicated in hours. The operating hours are stored with a resolution of 15 minutes. A number from 0 ... 999 999 999 h can be metered, the error being ± 2 min for 24 h. Simultaneously pressing both keys will reset the operating hour meter to 0.

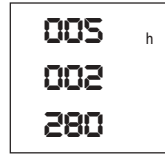

Representation of the number in the display starts at the lower right corner with the units digit, the counting direction being from right to left. The number shown in the figure, thus, is 5 002 280 h.

13. Energy measurement with impulse measurement (not with Option Profibus and RS232)

The MA 400 has two pulse outputs for measuring the active and reactive energy. The pulse outputs are accessible via terminals provided on the rear of the MA 400. They are wired as open-collector outputs so that an external voltage is required for operating the pulse outputs. The pulse outputs are metallically separated from the measuring voltage.

Voltage

5 to 24 V, max. 30 V_{DC}

Maximum switched current

27 mA (not resistant to short-circuits)

Pulse output terminal assignment

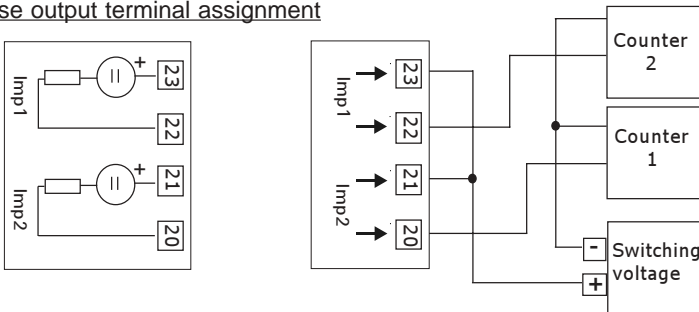

Imp1 = Pulse output 1

- active energy

Imp2 = Pulse output 2

- reactive energy

Connection of MA 400 to counters:

The electrical specification of the meters must match the specification of the pulse outputs of the MA 400.

As in the case of energy indication, one reversal preventing device each for the active and reactive energy is provided for measuring the energy via the pulse output.

For connecting an external meter, the pulse weight and the pulse length have to be set in the parameterisation mode.

13. 1 Entering the pulse duration

The pulse duration can be changed in the usual manner by pressing the MODE key. Values from 0.05 s through 2.00 s are available, the increment being 0.05 s. If a value > 2.00 s is entered, the display returns to 0.05 s.

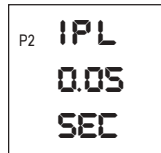

Pulse duration

Pulse time

Unit of time

Entering 0.00 will disable the pulse outputs. Once the desired pulse duration has been selected, it can be accepted by pressing both keys, and the next window will be displayed.

13.2 Entering the pulse value

The MA400 option Pxx will at first propose a value. The value proposed is the smallest possible useful value resulting from the input parameters, current and voltage transformer ratios and pulse duration. Entering a lower value may cause the connected meter to be no longer capable of coping with the frequency at which the pulses are received. A higher value can also be selected.

Pulse value for active energy pulse output

First, the unit of measurement is selected and acknowledged (by simultaneously pressing both keys). Then you can enter and acknowledge the numeric value in the usual manner.

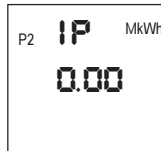

Pulse

Value

Pulse value for reactive energy pulse output

First, the unit of measurement is selected and acknowledged (by simultaneously pressing both keys). Then you can enter and acknowledge the numeric value in the usual manner.

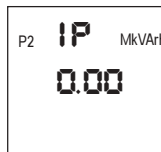

Pulse

Value

14. Technical data

Enclosure	96 x 96 mm ²
Mounting depth	< 58 mm
Terminals	direct screw terminals
rigid	up to 4 mm
flexible with wire end ferrule	up to 2,5 mm
Front side	membrane with two keys
Protective barrier	acrylic, colourless
Display medium	LCD
	3 x 7- segment display
	decimal points
	additional symbols
Display field dimensions	ca. 70 x 55 mm ²
Background lighting	none
Measurement value display	three-line, three-digit
Output signals	none

14.1 Inputs

Current	3 x 0 ... 5 A _{AC} 3 x 0 ... 1 A _{AC}
Overload current	20 % continuous
Overload short-time	20-fold for 1 s 5 repetitions after every 300 s
Voltage	3 x U _{Lx} to U _N
Voltage ranges	
Voltage U _{Lx-Lx}	3 x 100/110/ or 120 V _{AC} via voltage transformers 3 x 400 V _{AC} direkt 3 x 690 V _{AC} direkt
Permissible tolerance of voltage value	80 % ... 120 % of nominal

14.2 Display ranges and measuring errors

Voltage Lx-N	49 ... 76 V	< 1%
	196 ... 275 V	< 1%
	338 ... 438 V	< 1%
Voltage Lx-Lx	85 ... 132 V	< 2,5%
	340 ... 476 V	< 2,5%
	586 ... 759 V	< 2,5%
Maximum voltage to earth	< 300 V _{AC}	
Current	0,01 ... 1,00 A	< 1%
	0,05 ... 5,00 A	< 1%
Maximum voltage to earth	< 150 V _{AC}	
Effective power	0,2 W ... 999 MW	< 2,5%
Reactive power	0,2 VAR.. 999 MVAR	< 2,5%
Apparent power	0,2 VA ... 999 MVA	< 2,5%
active energy	0...999 999 999 kWh	< 2%
reactive energy	0...999 999 999 kVarh	<
2%		
Cos φ	0,10i ... 1 ... 0,10c	< 3%
Frequency (L1-N)	48 ... 62 Hz	< 1%
Dynamic range	1 : 500	

Additional errors f. computed measurement data

(The following errors relate to the end value unless stated otherwise.)

Influence of temperature	1,25 % / 10K ambient temperature change
Self-heating	0,5 % after 30 min
Influence of frequency	0,1 Hz / 10 Hz
Deviation from sinusoidal	2,5 % / doubling crest factor
Mutual influencing of measuring systems	1% /100 % value change of a measuring variable
External magnetic field	2,5 % / 0,4 kA/m
Unbalanced currents	2,5 % / current change of a current from end value to 0

14.3 Setting value

Voltage transformer, primary	50 V ... 999 kV
Voltage transformer, secondary	100V, 110 V, 120 V, etc.
Current transformer, primary	5 A ... 999 kA
Current transformer, secondary	1A, 5 A
Password (numeric)	00 - 99

14.4 Operating conditions

Ambient temperature	-10°C .. 15°C ..35°C .. 55°C
Storage temperature range	-20°C ... 70°C
Relative humidity of air	< 90%, no condensation
Suited for use at heights up to	2000 m above M.S.L.
Degree of protection	IP 54 front side IP 20 terminals
Class of protection	totally insulated, no protective conductor terminal (II)
Overvoltage category	III
Pollution degree	2
EMC	DIN EN 55022 (1998); 2001+A1:2000 (CISPR22) DIN EN 61000-6-2 (2002) DIN EN 61000-4-2 (1995) DIN EN 61000-4-3 (1996) +A1:1998+A2:2001 DIN EN 61000-4-6 (1996) DIN EN 61000-4-8 (1994)

Pin assignment

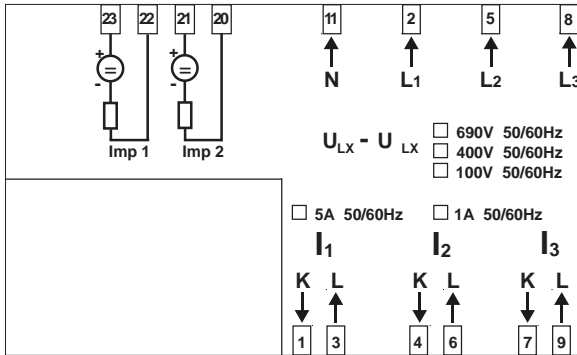

Rating plate

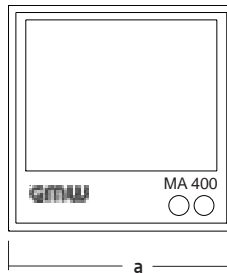
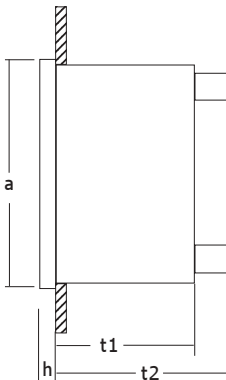
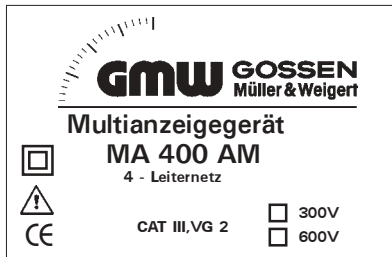

Mounting dimension

a	96 mm
h	5 mm
t1	43,5 mm
t2	58 mm

Sector $92^{+0,8} \times 92^{+0,8} \text{ mm}^2$

Mounting elements are lateral fasted

GOSSEN Müller & Weigert

Kleinreuther Weg 88

D-90408 Nürnberg

Tel.: 0911/3502-0 Fax: 0911/3502-307

E-mail: info@g-mw.de <http://www.g-mw.de>



Metrix Electronics Limited

Precision Enterprise House, Rankine Road,
Basingstoke RG24 8PP, U.K.

Tel: +44 (0)1256 864150, Fax: +44 (0)1256 864154

E-mail: sales@metrix-electronics.com

Web: www.metrix-electronics.com

