

### Application 1: Automatic fruit juice composing system

Logical functions implemented in SIMEX Multicon CMC-99 makes simple control procedures available. Depending on tanks level our device switches batch valves. After finishing whole sequence our controller switch the pump on. Those levels are seen on CMC-99 screen. There is a possibility to implement some outputs as an alarm signals. There are simple controller and HMI unit collected in one single device. There is no need to create visualization application and control procedures separately.

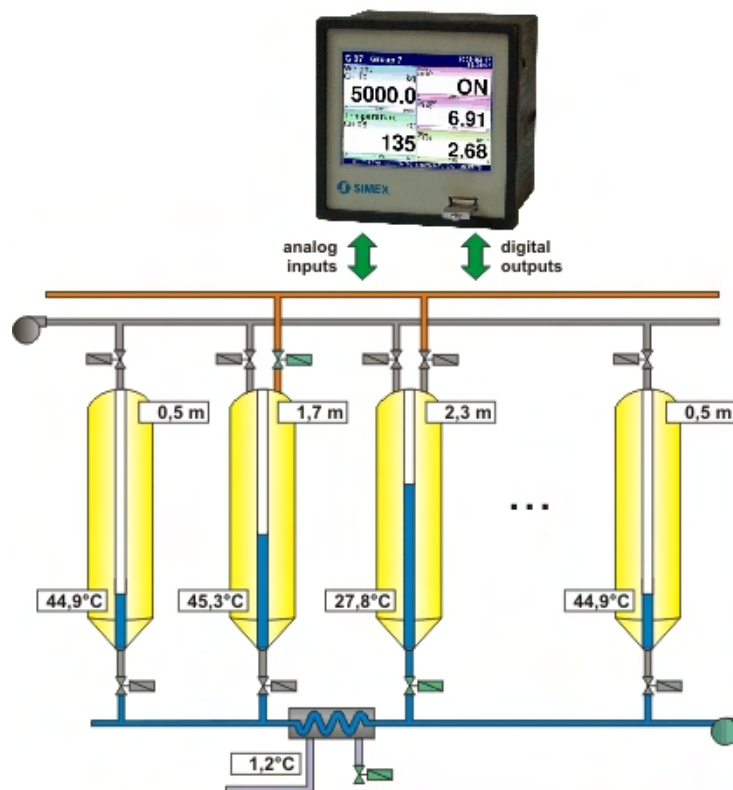

### Application 2: Analog measure points concentrator system

In this kind of industry application CMC-99 collects all analog measurements and sends them through Modbus RTU to main PLC. The distance between CMC-99 and a PLC installation can be up to 1000 m. All measurements are sent using one cable, this is a very cost effective method. Modbus RTU is very popular and reliable communication protocol. There is a possibility to divide Modbus network into several subnets. CMC-99 can work as a Master in one subnet and as a Slave in another.

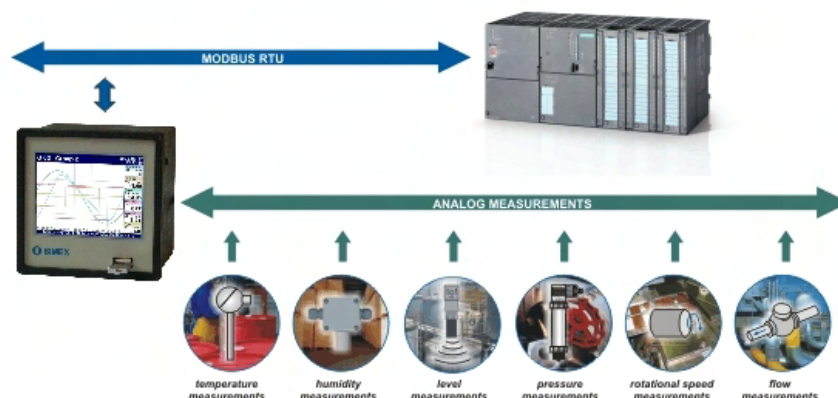

### Application 3: Distracted application structures

MultiCon CMC-99 collects all analog measurements using Modbus RTU protocol as a Master mode. All data are sent to another device (e.g. PLC) using one single cable. Today it is the most advisable communication method. It is very useful in distracted application structures. Modbus RTU protocol can be used in explosive ATEX zone as well. There is no need to extend system. All analog measurements are collected together and seen on CMC-99 screen. Our Controller can be extended up to three Modbus RTU subnets. For example introduced above another subnet connects CMC-99 with a PLC. PLC is a Master and the Multicon is a Slave.

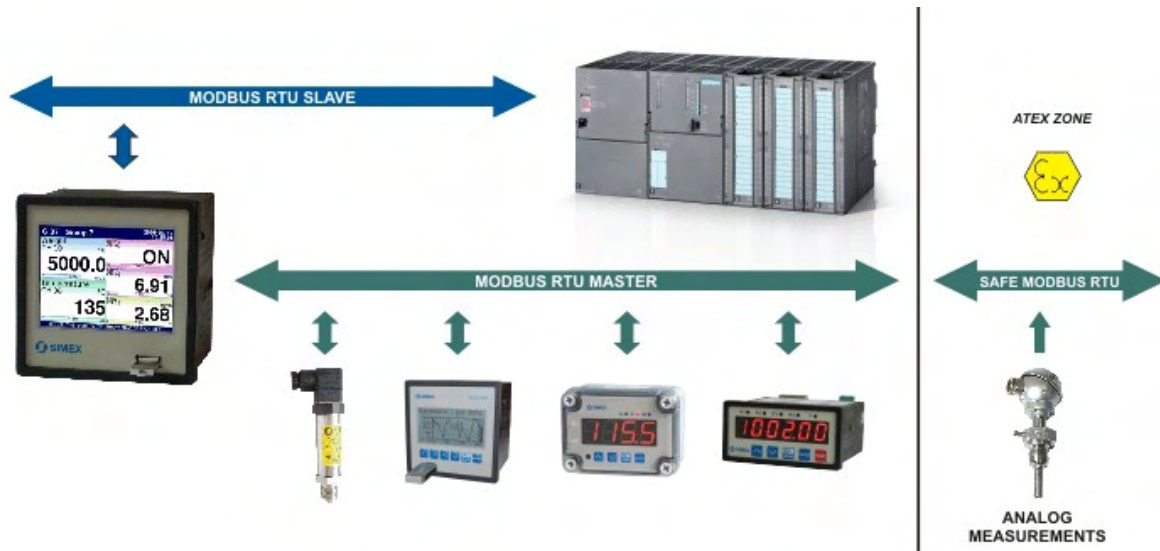

### Application 4: Industrial automation trends

Nowadays industrial automation trends are going towards miniaturization and universalization. Outdated and unreliable systems like synoptic control boards can be now replaced with multi-purpose single devices. Today meters/controllers should be able to meet many customers specific needs. MultiCon CMC-99 is an ideal solution for applications where simultaneous measurement and regulation of numerous channels are required. All control functions are collected in one single device. CMC-99 is equipped with colour TFT touchscreen that makes HMI simple applications possible. It is a very time saving facilitation. Plenty of screen types allow to visualize different measurements very clearly. Even complicated automation process can be implemented in MultiCon easily. Different types of inputs are joined with virtual channels. Using those channels and built in control methods Simex MultiCon CMC-99 covers almost every industrial automation process.

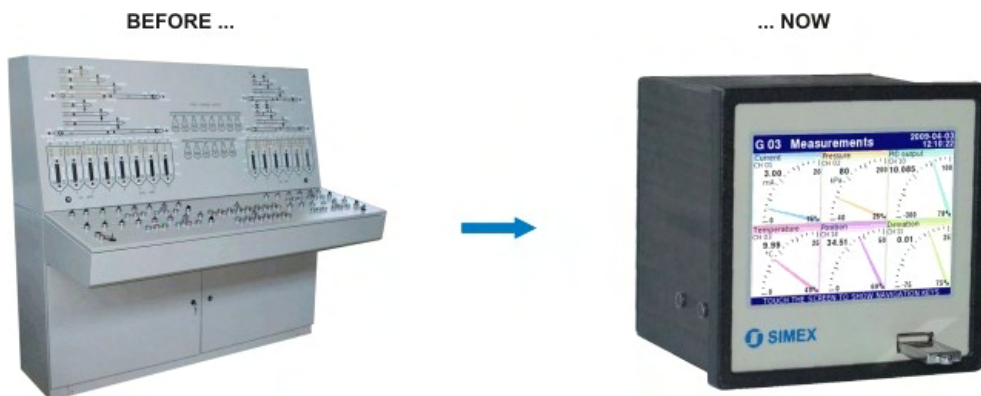

## Application 5: Expanded mathematical functions

MultiCon CMC-99 controller allows to operate logical channels with mathematical functions. One can change every channel value using arithmetic operations. This possibility is very useful when CMC-99 should work for example as a signal circuit analyser for monitoring eg.: power, power factors and electric energy. Having only voltage and current as input channels, all mentioned values can be calculated using mathematical functions only. The result of arithmetic operation is also an input channel and it can be displayed on CMC-99 screen or connected with our controller's output. Using binary logic as arithmetic component MultiCon CMC-99 gives you a great possibility to implement simple PLC industrial application control systems.

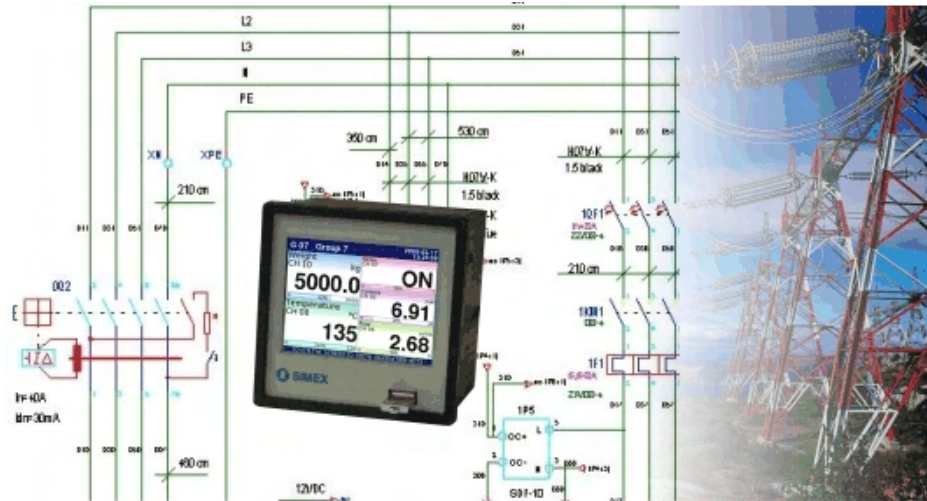

## Application 6: User's simplification

Simex MultiCon CMC-99 controller has a lot of parameters and functions to set up. They make this device more versatile and they can cover our customers specific needs. Extended options, that CMC-99 device has, can make set working process time-consuming. Luckily two USB Host ports are available. One can plug a PC mouse and keyboard to fasten configuration and programming process. Although each CMC-99 is supplied with a scribe, an operator can also use a PC mouse for easy configuration, especially if one has to configure many CMC-99 units at the same time.



## Application 7: PID loop systems

Nowadays industrial automation trends are going towards advanced controlling systems. SIMEX MultiCon CMC-99 has up to 5 separate PID controllers. Even very enhanced industrial application can be supported with CMC-99 device. It is obvious that PID loop applications are cost and energy effective control systems.

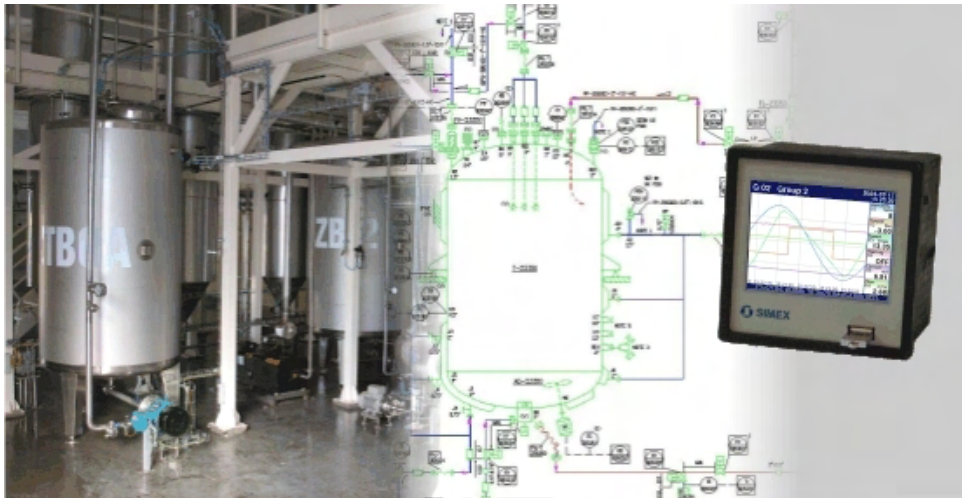

## Application 8: CMC-99 temperature meter

As a great example of CMC-99 universal functionality is our latest successful story. Multicon CMC-99 collects measurements from 12 temperature points and sends them to the SimCorder software which logs them in a file. The customer uses one CMC-99 only to view all the measurements at one place. Great facilitation is that our device has dedicated input slots for temperature sensors either resistance or thermocouple. There is no need to use additional devices like eg. external transmitters.



## Application 9: High current relay outputs

A great amount of available controllers have built in relay outputs, but MultiCon CMC-99 has high current relay output slots as an option. The unit can be equipped with 4 Relays 5A current load built in one single slot. For example CMC-99 having this relay output module in, can control heaters with 1200W load. Furthermore CMC-99 users don't have to install contactors or indirect relays in their applications, which significantly can save space in electric cabinets. When contactors or indirect relays are necessary in any way, Multicon CMC-99 has 24V DC power supply excitation, in order to drive their coils.

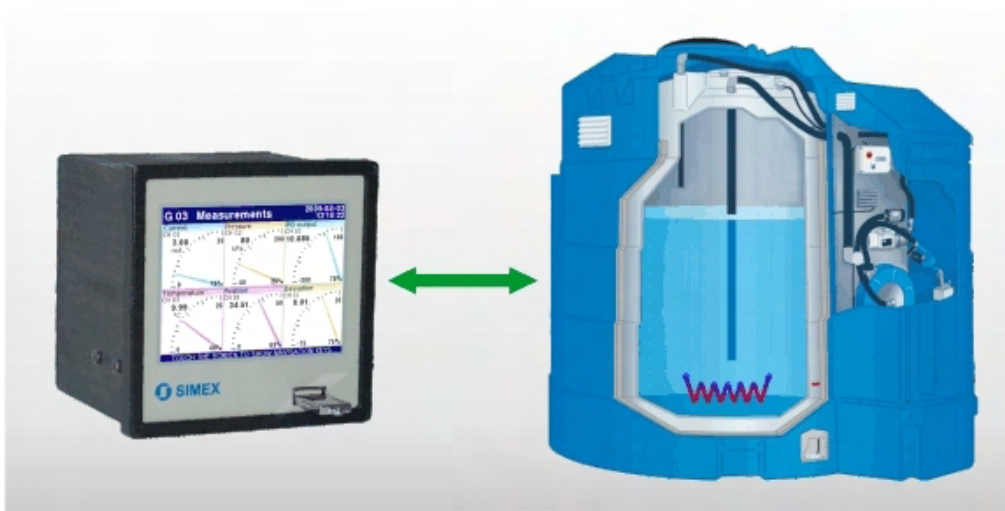

## Application 10: Fast SSR outputs

A great deal of industrial automation solutions needs fast durable outputs. MultiCon CMC-99 is now ready to meet the requirement due to the SSR output available as another PCB module. Fast SSR output can be driven down to 0.1 sec time period. As an example, typical production lines require fast working controllers. Simex MultiCon CMC-99, with its colour display and visualisation possibilities covers our customers needs perfectly.

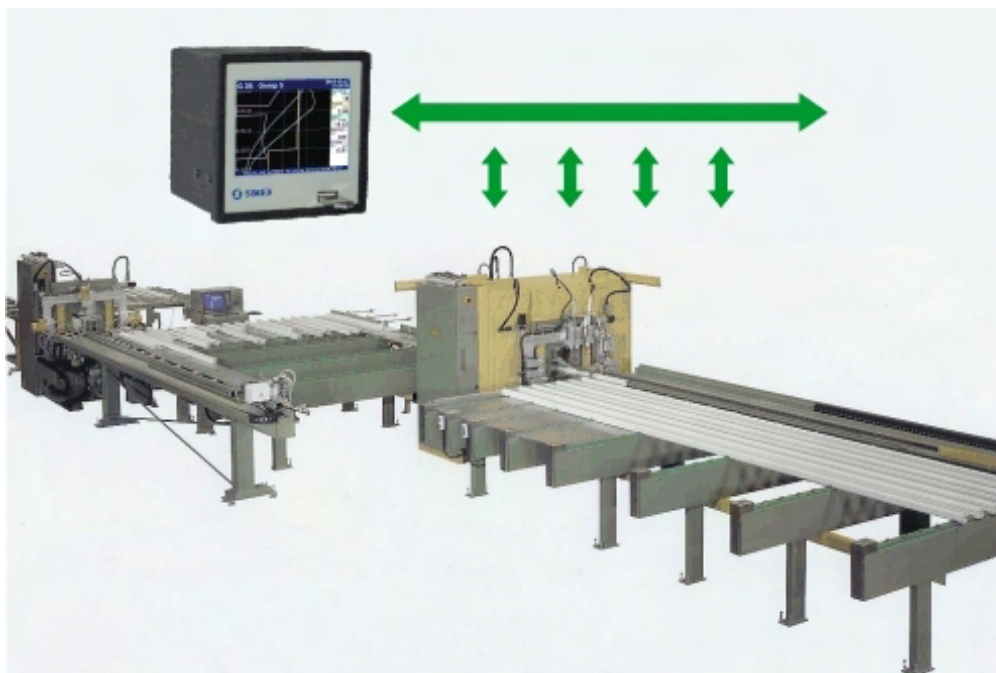

## Application 11: CMC-99 scatter application

Thanks to Advanced Communication Module available as another slot in CMC-99, there is a great possibility to implement scatter applications using all Simex and other devices equipped with RS-485 port. MultiCon's Modbus RTU Master has many settings that make demanding and complicated applications possible to realize. Intermediate pumping stations scatter in wide distance is a good example of CMC-99 universality. Options like Modbus Time-out are very useful for eg. GPRS communication.

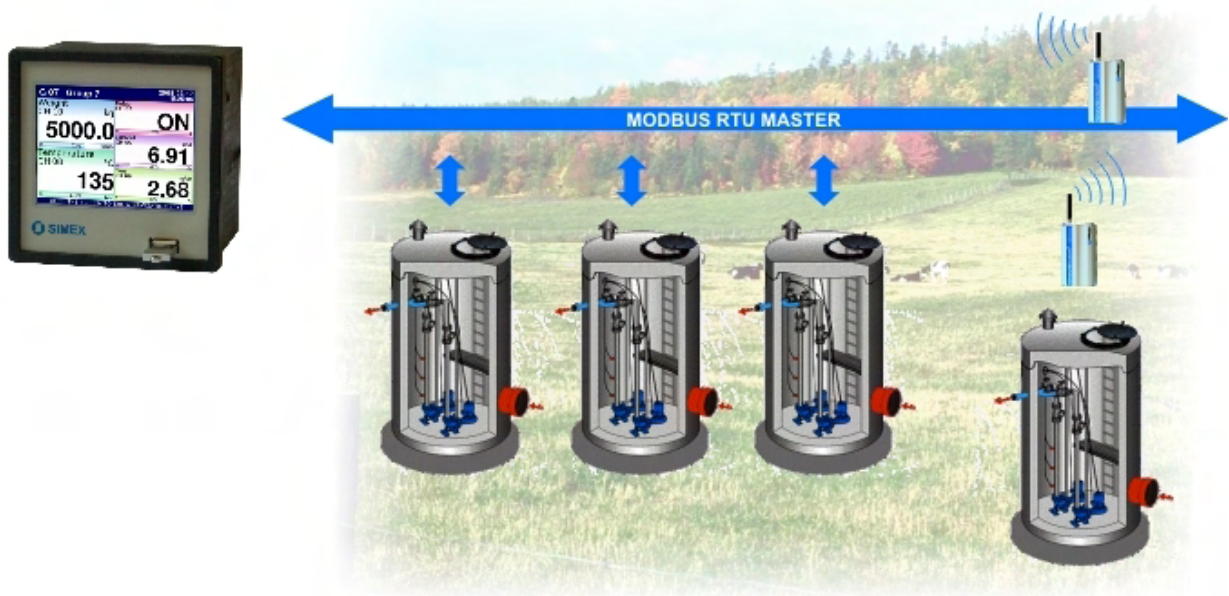

## Application 12: Auto configuration for Simex devices in CMC-99 Modbus RTU interface

Multicon CMC-99 Modbus Master communication options may not be obvious for non experienced maintenance engineers. We have made readymade settings for all Simex devices equipped with RS-485. To set it up one just has to choose a device from the list in the CMC-99 menu. There is no need to change any Modbus option. Communication will start and function automatically.

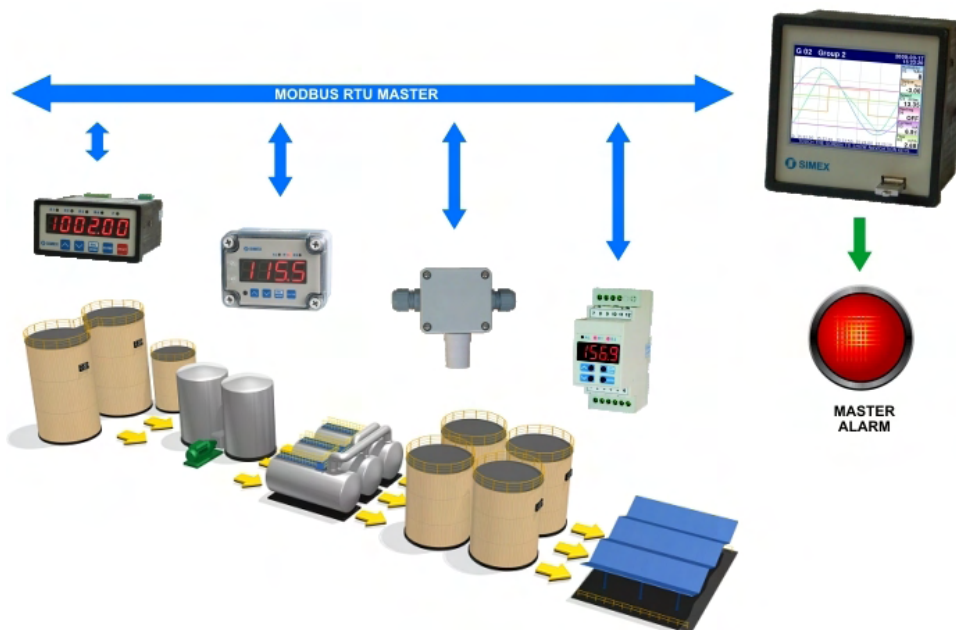

### Application 13: CMC-99 date and time controller

Many typical automation applications are time period. It is very unprofitable to make an investment with expensive PLC if control applications are relatively simple. The Multicon CMC-99, thanks to implemented timer system, has a great possibility to control those systems alone. Using different input and output slots one can design as complicated automation systems as PLC, but inexpensively.

As an example, gardening industry needs controllers with date and time functions.



### Application 14: Precise analog outputs as a new CMC-99 slot

Thanks to available Analog output module, there is a great possibility to control industrial applications using continuous analog signals. There are 4096 divisions available. Using profiles function one can compose even very complicated controlling. Chemical and pharmaceutical applications that need complicated composing systems are easy to implement with CMC-99.



## Application 15: MultiCon CMC-99 the scatter controller

Taking into consideration actual industrial trends, we are pleased to introduce the Multicon CMC-99 as a scatter controller. There is a Simex family of digital I/O, counter and analog input external modules, implemented in a small housing, that are easy to built inside control boxes. A single cable connection with RS-485 as a Modbus RTU makes applications economical and noise robust. The CMC-99 can be used as the net Master that works out outputs using information collected from different inputs. Scatter solutions are very common when industrial applications occupy a lot of space.

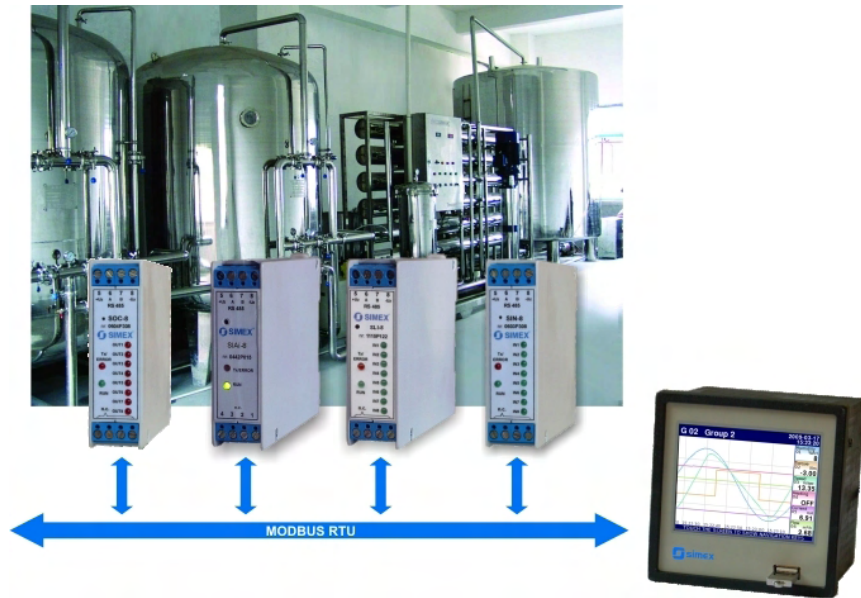

## Application 16: New TS-35 DIN rail holders

Sometimes there is a necessity to build CMC-99 inside a control box. Using a common TS-35 DIN rail and new, optional Multicon CMC-99 DIN rail holders, the controller is easy to assemble in such applications. This way of installation is very helpfull if access to this device has to be protected against unauthorized personel or high IP protection is required.

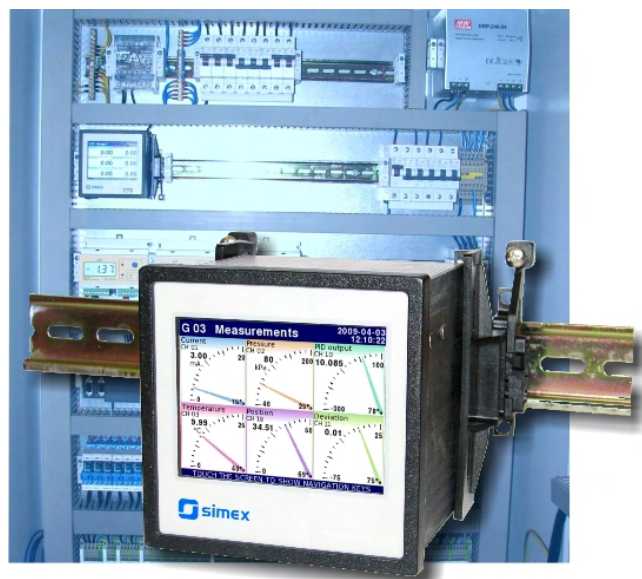

## Application 17: MultiCon CMC-99 screen using web browser

MultiCon CMC-99 is well known as a universal meter and data logger. The unit is capable to collect different type of measurements coming to the input modules or transmitted via Modbus RTU port. Now, thanks to the Ethernet port build-in optionally, CMC-99 gets a new functionality - display channels can be selected and viewed using typical web browser. The device can have a static or dynamic IP address (DHCP mode) which enables you to introduce CMC-99 to a corporate network.

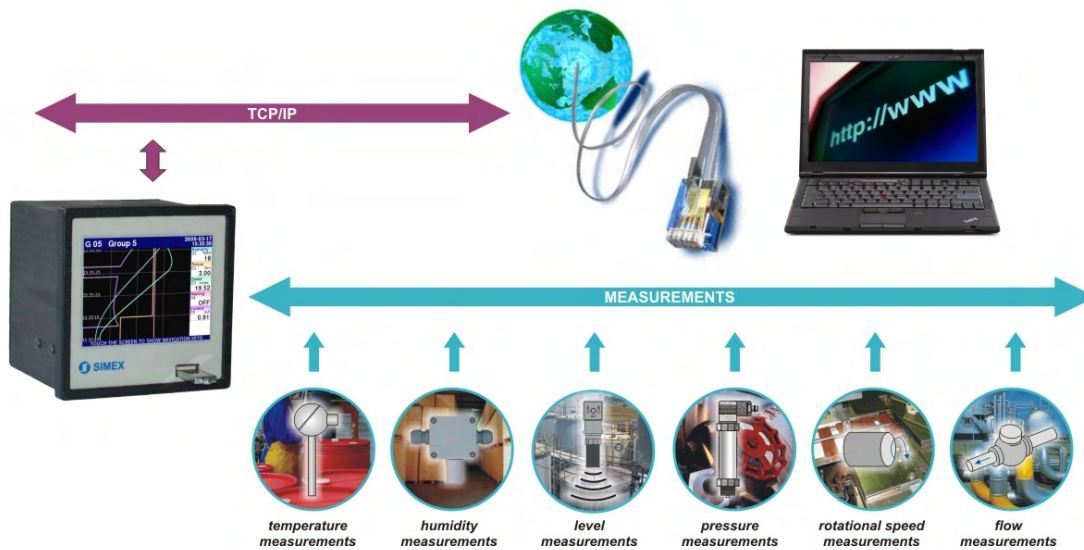

## Application 18: MultiCon CMC-99 data logger

Taking into consideration current industrial trends, there is usually a requirement to control actuators and log data using a one single device. In this case CMC-99 is the right choice. Using the software licence key a customer can activate data logging functions. Recorded data can be moved to the DAQ Manager PC software with a USB flashdrive. The DAQ Manager allows to analyse recorded measurements using tables or graphs. Data can even be exported as a file for use in other customer programs for further analysis.

