

# MultiCon = Meter + Controller + Recorder + HMI in one package, part I

## Introduction

The MultiCon series devices are advanced meters, controllers and recorders closed in one compact case. They have been designed for both advanced and less demanding applications in industrial automatic control engineering. They feature a colour TFT display with a touch screen (3.5 or 5.7 inch, depending on version). Such a GUI is a pleasure to work with, and the operation of the MultiCon playing the HMI role is intuitive and comfortable. The kernel of the software is LINUX operating system, which ensures stable operation and enables installing advanced software.



Fig. 1: Possibility of operation via a touch screen, a keyboard or a mouse

## Possibilities

At first glance, the absence of any keys on the instrument front panel comes as a surprise. However, operation using the touch screen is much more efficient and comfortable. The operation philosophy is analogous to generally known windows systems: hitting (clicking on) appropriate menu keys, sliders to move the screens, etc. If, however, you are not happy with the touch screen, a traditional keyboard and a mouse can be connected to the instrument through USB ports to make the operation extremely simplified.

Despite its compact dimensions the instrument has huge application possibilities. A well-thought-out modular design allows precise adaptation of the CMC to various specific needs and requirements of all customers. Available is a wide array of input and output modules (current, voltage, universal, thermocouple, RTD, digital, counting, relay, SSR and other).

In its most expanded version, a single, compact CMC-99 instrument can include modules which provide in total up to 48 physical inputs and outputs (analogue, digital and relay). Its slightly bigger brother, CMC-141, can have fifty percent more inputs and outputs. Figure 2 shows the CMC-99 rear panel for one of the most typical configurations often ordered by our customers.

You do not need to use all slots; what's more, when a modification becomes necessary all you need to do is send the instrument to an authorized distributor who will introduce the changes, adding, removing or replacing modules.

The most demanding users, for whom a single RS-485 interface in the standard version is not enough, can choose the ACM (Advanced Communication Module) with additional communication interfaces: Ethernet, USB, RS-485 and RS-232 shared with another RS-485.

Using the Modbus RTU, the MultiCon CMC can read data and control outputs of other devices in the network. External inputs/outputs (i.e. inputs and outputs for other devices) are particularly useful when there is a need to control a large number of physical execution units or collect data from distant sources. The number of these inputs/outputs is counted independently of the inputs/outputs available on the built-in modules. This additionally augments the potential of MultiCon which is powerful already. In this way, using a MultiCon CMC you can build an advanced network system where you can monitor the operation of the whole from any place on the planet, e.g. via Internet.

Each MultiCon can work also as a data recorder. Its internal memory of 1.5 GB is sufficient for over 125 million of samples, meaning that even in the intensive sampling mode (every second) you can record data, for example, from 24 channels for 2 months.

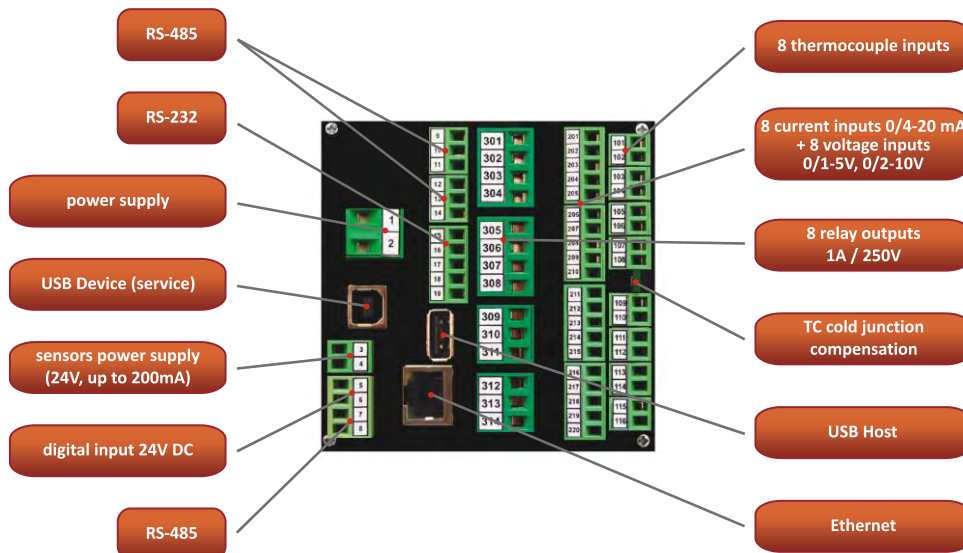

Fig. 2: Example of input/output hardware configuration

### Block internal design

In order to understand why such a small device meets so many different requirements, it is necessary to have a closer look at its internal design.

The heart of the device is a powerful, 32-bit ARM9 processor to which typical peripherals are connected: flash memory with firmware, flash memory for data recorder, RAM, TFT graphic display with a touch screen, power supply systems, basic communication interfaces, etc.

The device system is based on Linux, which allows – with suitably thought-out software - to use MultiCon to implement even many independent tasks at the same time (also in large multi-channel systems).

For detailed description of more interesting software functionalities (including logical channels, mathematical operations on channels, timers, profile generators, single and multiple PID controllers, etc.) please refer to part III of the articles on MultiCon CMC.

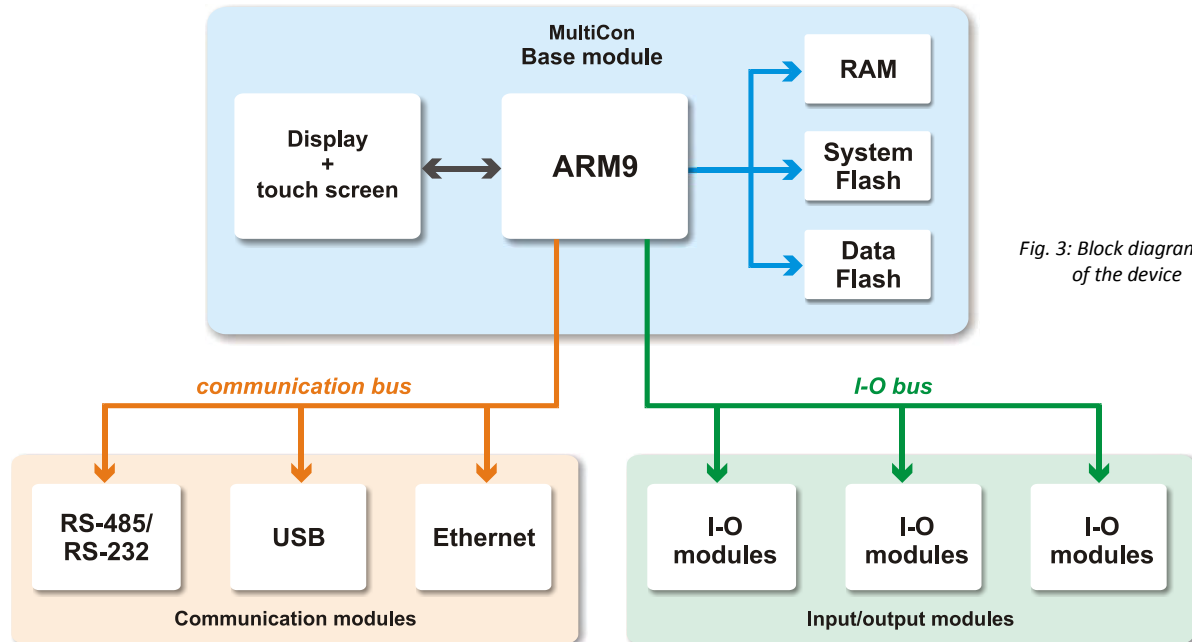

Fig. 3: Block diagram of the device

Please note, however, the way the I/O modules are connected. To reduce the load on the CPU and ensure fast implementation of system tasks, including immediate response of the TFT display (the laboratory tests of hardware possibilities have proved that e.g. viewing films or cooperation with a USB internet camera with advance processing and image displaying in real time is not a problem), all optional measurement and communication modules are equipped and supported by their own efficient RISC processors (AVR family) and they are connected with the main processor via a fast serial bus. Therefore, all tasks related to e.g. A/D processing, calibration, transmission frames support, etc. are performed directly on the modules. As a result, even with the maximum number of modules connected, the device speed is not affected, and expanded internal firmware of the modules ensures very good accuracy and stability of measurements.

As a result of cooperation with the users, the software is constantly developed and new, useful functions are added. Interesting additions or solutions are quickly implemented as firmware updates. A free update feature is provided so that all MultiCon CMC users always have the latest firmware version installed on their devices. The update procedure cannot be simpler: just download the latest files from our website, write them on a pendrive, connect the pendrive to CMC and start the process - the rest is fully automatic.

Such a design solution allows also an easy introduction of a very important element: galvanic separation of all external connections in all modules to significantly increase the device functionality and flexibility.

### More articles

This article presents only the MultiCon general features - modular design concept and outline of the device possibilities. The next article will be published next month and it will show the software potential using the TFT touch screen, results presentation in the digital data format or as analogue indicators, colour graphs displayed on the screen in real time, bar graphs, etc.

### Software

After powering on, the operating system is loaded from the flash memory to RAM, followed by the application software. The before-mentioned, specially designed bus connecting the modules, including an internal communication protocol, allows an immediate detection, identification and recording of each newly installed module. Suitable configuration modules are activated simultaneously which ensures full implementation of the PnP function.



Measure, Control and Log data

SIMEX Ltd.

Wielopole 7, 80-556 Gdańsk

tel: (+48) 58 76-20-777, fax (+48) 58 76-20-770

www.simex.pl, e-mail: [info@simex.pl](mailto:info@simex.pl)

# MultiCon = Meter + Controller + Recorder + HMI in one package, part II

In the previous article we presented a concept and features of the MultiCon series devices and the outline of their possibilities obtained as a result of well developed software and a modular design. This part will describe other advantages, including simple operation and configuration using a TFT with a touch screen, a thing well know from such devices as smartphones or tablets.



Easy change of data presentation and displayed channels is a feature which might be useful in many cases. MultiCon offers numerous possibilities in this area – the basic function is bringing up the contextual menu by touching the display briefly. Then, a set of buttons appears on the bottom of the screen to switch between the display modes, channel groups or to enter the menu (Fig. 1).

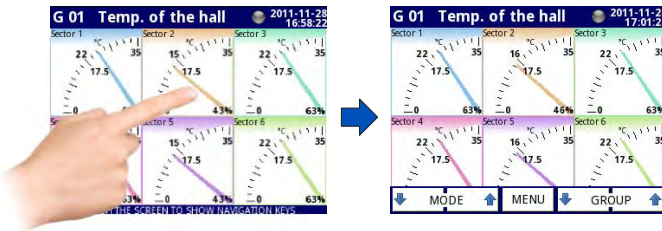

Fig. 1: Contextual menu

The “MODE” buttons allow a quick selection of data presentation method on the screen. Depending on whether we need a detailed information on the signal value, quick insight into the signal level, or parameter trend over time, the data can be presented as:

- numerical values - Fig. 2a
- needle dials - Fig. 2b
- horizontal or vertical charts - Fig. 2c
- horizontal or vertical bars - Fig. 2d
- simultaneous presentation many groups - Fig. 4



Fig. 2: Basic data presentation modes on the screen

In the first four modes, the panels present in a clear manner the name and the unit of measure which are specified and entered by the user, its graphical or numerical representation, and in addition a percent value in relation to a set level. The last mode allows to present as numbers up to 30 channels on one screen. This mode is particularly comfortable in MultiCon-141 equipped with a large 5.7” display.

The time graph data presentation mode is useful for recording operation. Depending on the configuration, the graph background can be black (Fig. 3a) or white (Fig. 3b, 3c), and the graph itself can be set as horizontal (horizontal time axis – Fig. 3c) or vertical to maintain conformity with traditional paper recorders (Fig. 3a, 3b). The user can also set the line thickness.

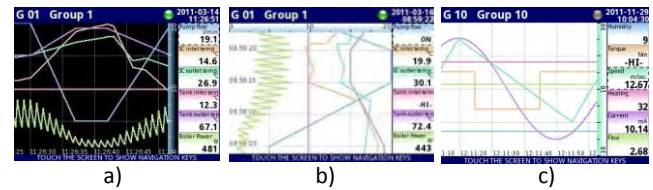

Fig. 3: Data presented as a graph

For the sake of clarity of results, the measurement channels are assigned to groups. The “GROUP” buttons are used to select the group which will be displayed. Figure 4 presents a mimic board view with 30 channels from groups from 1 to 5. Using the “GROUP” buttons will change the range of displayed channels; this also applies to all other data display modes.



Fig. 4: Simultaneous presentation, groups 1 to 5

MultiCon CMC-99 has 10 groups, and MultiCon CMC-141 has 15. A single group can contain maximum 6 channels, but the channel assignment to groups is not restricted, and the same channel can be displayed in many groups, providing the user with full flexibility to group various indications (e.g. one room, the same equipment, groups of measurements of the same type, etc.). For example, Fig. 5d shows a group related to one physical equipment. Selecting the number of channels assigned to a group, we can obtain different sizes of various indicators (Fig. 5).

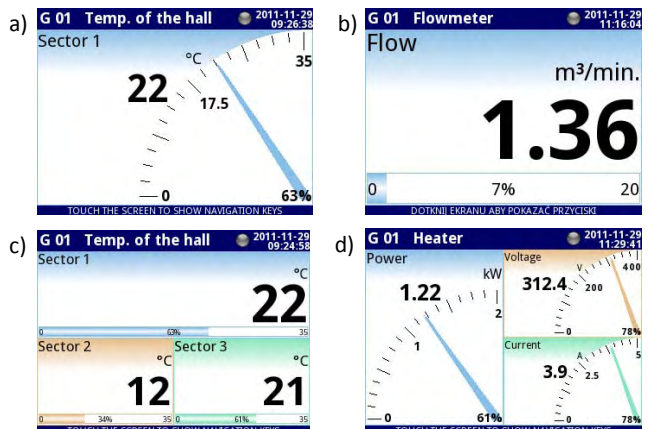

Fig. 5: Presentation of individual data groups

At this point, it is worth emphasizing the mathematical capacity of MultiCon devices. In Fig. 5d, the channel "Power" is calculated from the "Voltage" and "Current" channels by setting the multiplication function - but this feature will be dealt with in more detail in part III.

The MultiCon series devices equipped with the ACM (Advanced Communication Module) allow also a very easy remote monitoring of measurement results using a web browser, as well as a very attractive graphical presentation in the form of built-in or user-created websites. Along with the device, the manufacturer supplies a set of built-in Java applets which using the Modbus TCP protocol provide the programmers with easy mechanisms to retrieve data from the device, as well as ready-to-use formats of data presentation on the computer screen. An example of such a website is shown in Fig. 6. As you can see, its appearance and structure depend only on the programmer's ingenuity.

In order to facilitate the use of their own websites by the users who do not know HTML, Simex has prepared a few examples which are distributed with the free DAQ Manager software used to manage the data recorded by MultiCon.

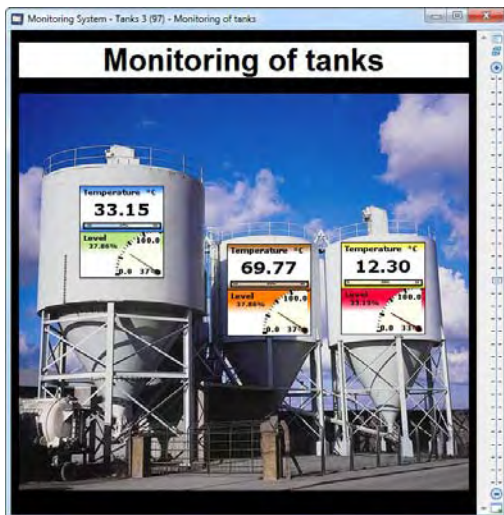

Fig. 6: Example of a website created using the Java applets

Press the "Menu" button to enter the main menu of the device (Fig. 1). If the menu is password-protected, a window will appear with a request to enter the password. Access to menu gives a user extensive freedom to configure the MultiCon, and without knowing any programming language! Here are some options available from the menu level: results presentation mode, panel appearance, measurement ranges and indication ranges, assignment of channels to groups, language (including Polish, English, German, Russian, French, Spanish, Romanian, Czech), channel operation modes, disk operations, device data, configuration of communication interfaces. Let us focus on the presentation of results.

MultiCon allows a very precise configuration of the data display method, in particular it allows to specify the names and units shown in individual channels, rescale the measurement data and set ranges in the indicator and graph modes. A particular case – binary data can be presented not only as 0/1. Any text can be assigned to the logical states. For example (Fig. 7a), the "ON" string on the green background is assigned to the "0" state, and in the "1" state the display will show "OFF" on the red background. Setting a string of spaces instead of the text, we get an imitation of a control light which lights up in any colour the programmer selects for a given state.

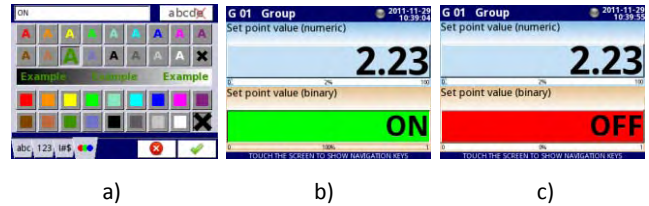

Fig. 7. Configuration of binary data presentation: "Setpoint" mode

It is absolutely necessary to mention one more data display mode - "Setpoint" - although it is more related to the channel operation mode than presentation of results. Touching the screen in the field of such configured channel, the user can in no time at all change a fixed value assigned to the channel (e.g. a threshold in the controller). In addition, this mode can be mixed with binary data presentation as described above (Fig. 7b, 7c) which allows an easy definition of function keys on the screen. The other interesting feature of the "Setpoint" mode is access to the settings. Depending on the needs, the admin can configure a channel so that the changes are made only by authorized users or any operator, also the one who does not know the password.

As a piece of interesting information, let us here present a "trick" - a quick access to group settings or settings of channels in a group. Instead of entering the menu and selecting the channel from the list, you can just touch and hold the screen in the area of the channel that interests you and you immediately enter the editing of this channel's parameters (Fig. 8). Operation of the group is similar: press and hold the top bar on the group name and you enter a relevant submenu.

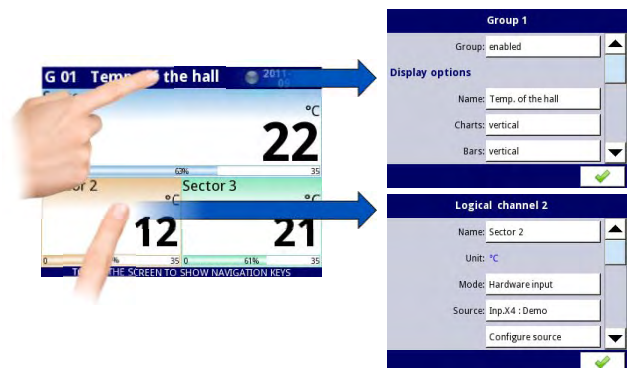

Fig. 8: Editing the group and channel

The next article will be dedicated to the firmware potential in terms of controller applications (including multiple PID controllers), mathematical capacity and operation in various communication networks.



Measure, Control and Log data

SIMEX Ltd.

Wielopole 7, 80-556 Gdańsk  
tel: (+48) 58 76-20-777, fax (+48) 58 76-20-770  
www.simex.pl, e-mail: [info@simex.pl](mailto:info@simex.pl)

# MultiCon = Meter + Controller + Recorder + HMI in one package, part III

In the previous articles we presented the device design and options of presentation of results and operation using the touch panel. To have a full picture of huge potential of MultiCon, now we will focus on processing measurement data, control functions and possibilities of cooperation in network systems.

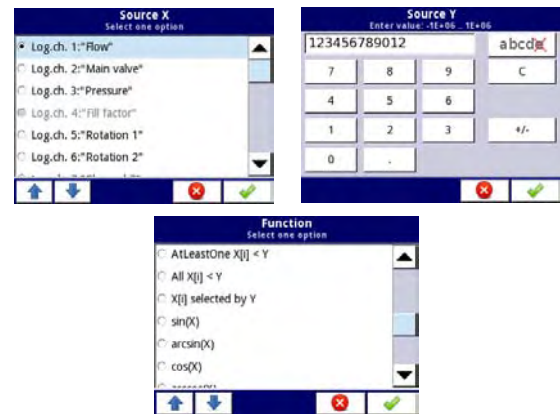

Fig. 1: An example of mathematical function

The distinguishing feature of MultiCon is its capability of simultaneous implementation of tasks related to measurements, processing, control and recording of data. To make this possible, the designers have used the concept of "logical channels" which are virtual bridge between physical inputs/outputs and control and visualization processes.

An expanded configuration menu of logical channels allows for a very precise configuration. It will not suffice to mention the names, units of measure, precision of displayed data or ranges of indicators and graphs. The designers provided for easy rescaling of collected data, as well as filtering or data hold controlled by another channel.

In the MultiCon devices, it is the user who decides how to use the available logical channels. The parameter which allows to select the channel function is the "operation mode". It can be set so that the logical channel:

- represents the data from physical inputs and outputs;
- processes the data from other logical channels using the mathematical and logical functions;
- generates constant values (set points) or sequence diagrams (profiles);
- works in the PID controller mode;
- constitutes a virtual function key.

Relationships between channels (including mathematical operations on the values) can be set directly in the device and it is not necessary to know any programming language. As the essence of any data processing is mathematical operations in the device, many standard functions have been provided to build complex algorithms.

In addition to the basic mathematical functions, such as addition, subtraction, multiplication and division, the device allows, amongst others, to use trigonometric functions, calculate the mean or maximum or minimum value from any number of channels, as well as logical functions or comparison and election. The source of data in mathematical functions can be of course other logical channels and constant values set in the menu.

One of the most important functions of MultiCon is a controlled configuration menu of built-in outputs (e.g. relays) which allows to use them directly as so-called two-position controllers.

Free combination between inputs and outputs allows to create easily multi-channel controllers operating totally independently. In addition, the concept of logical channels provides an opportunity of making many outputs (including outputs of different types) dependent on a single input channel, and introduction of mathematical operations significantly expands the control options.

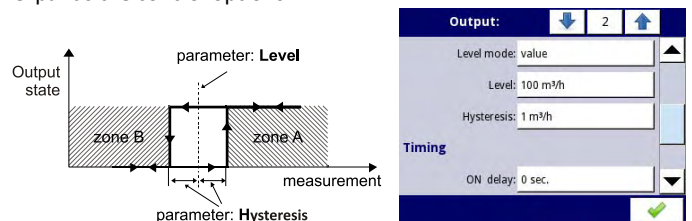

Fig. 2: Operation principle of ON/OFF controller and a fragment of relay menu

In addition to ordinary ON/OFF control using binary signals, MultiCon allows PID control using built-in and external analogue outputs or SSR outputs in the PWW mode.

Each of 60 logical channels can be set in the PD, PI, PID controller modes with an independent set point, input and output. The user can choose from 8 sets of PID control parameters (available in the "Controllers" submenu) each of which can be assigned to many logical channels operating in the controller mode. This is a perfect solution when many similar processes need to be controlled. The MultiCon can work then as a unique multi-channel PID controller.

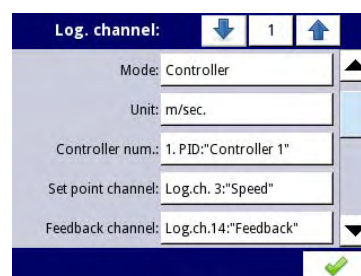

Fig. 3: Basic logical channel settings in the PID controller mode

A necessary supplement to the control functions of the device is a possibility of automatic change of the set value – timers/profiles – which allow for generating signals of a user-defined waveform and duration. What's important, the MultiCon allows to define profiles even 100-section long, and the duration of each of them can be different. Additionally, looping can be introduced. You can also define the trigger moment and method (e.g. by a state of another channel or a RTC clock). Thanks to such flexibility the selected process can be launched cyclically, e.g. on a set day of the month at a set time, with additional conditions.

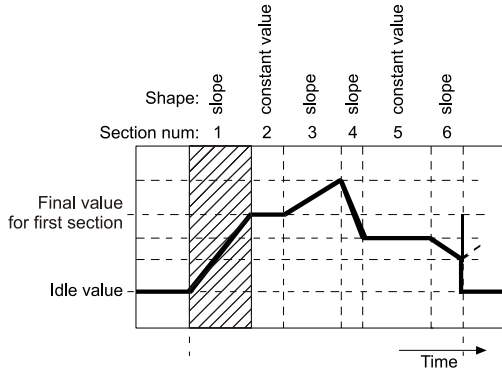

Fig. 4: An example of time profile with variable section lengths

Undoubtedly, an advantage of MultiCon is that it can cooperate with other devices and systems. The basic configuration includes a single RS-485 port with the Modbus RTU interface. It is however sufficient to add an ACM module to increase the application potential many times. This module is equipped with isolated RS-485 and RS-485/232 ports, an Ethernet interface and an additional USB Host port. Each of serial ports is a separate interface with Modbus RTU protocol and can operate independently of the others, both in the Master and Slave modes.

Expanded communication possibilities are particularly useful when it is necessary to control a very high number of physical execution units or collect data from many distant sources.

Via Modbus RTU, MultiCon can use external inputs/outputs (i.e. inputs and outputs for other devices) just as it uses the built-in modules – it can read data and control the outputs of other devices present in the network. In addition, in the Slave mode it is possible to write data in individual MultiCon logical channels (up to three at a time). Combining these options, MultiCon can be a programmable network hub.

The Ethernet interface was described in more detail in part II, so let us just turn your attention to implementation of the Modbus TCP protocol which allows to connect the device with other systems via Internet. Using the world wide web, you can also control the device and download data on-line using dedicated software. More importantly, all tools are available free of charge right on the manufacturer's website.

### Summary

We do hope that this cycle of articles has introduced to some extent the great potential of these devices, quite incomparable to their small size, and that it will encourage the readers to create applications using them.

The device is constantly developed, the measurement options are expanded, new software improvements are made, new functionalities are introduced as requested by the users of industrial applications. If as of today, the users believe that the device lacks some specific options, we suggest they directly contact SIMEX. Perhaps, the missing functions are just being developed. A specific modification can also be ordered by a customer. Functions like these are not provided by any competing device available in the market.



Measure, Control and Log data

SIMEX Ltd.

Wielopole 7, 80-556 Gdańsk

tel: (+48) 58 76-20-777, fax (+48) 58 76-20-770

www.simex.pl, e-mail: [info@simex.pl](mailto:info@simex.pl)

Fig. 5: Manage a developed network of devices

