

SRL-49

- ▣ process meter with bargraph
- ▣ input 0/4-20 mA, 0/1-5V, 0/2-10V
- ▣ 0, 2 or 4 relay outputs (or OC)
- ▣ RS-485 / Modbus RTU
- ▣ option: active current output



The **SRL-49** process meter features current input with protection safeguarding the measuring resistor against damage. The measurement is visible simultaneously on the 4-decade LED display and 20-point, two-colour bargraph reflecting 0-100% of measuring range. The set threshold values are also shown on the bargraph, and the LEDs indicate when the values are exceeded. The device operates in the following modes: linear, root, square and user defined (max. 20 points). 2 or 4 relay (or OC) outputs enable adjustment of the level of the measured signal. These outputs can be controlled according to one or two threshold values.

- programmable measuring range,
- programmable hystereses and delays of control outputs,
- password protected,
- programmable indication filtration,
- overload-protected current input.

Typical applications

1. Measurement of pressure in pipelines with air pressure control by means of the frequency inverter and signalling of minimum and maximum thresholds.

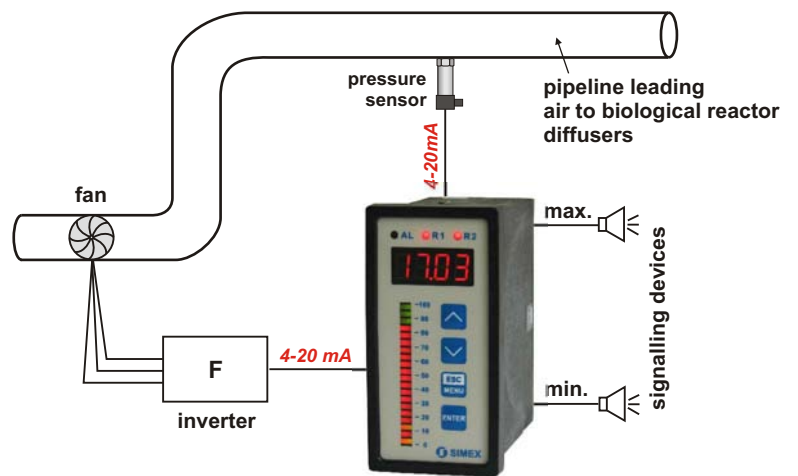

Exemplary pin assignment

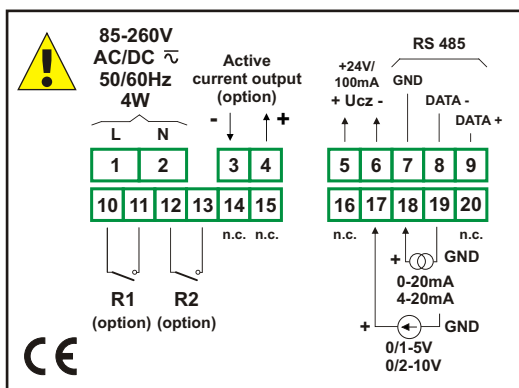

Technical data

- Power supply:** 19V ÷ 50V DC; 16V ÷ 35V AC or 85 ÷ 260V AC/DC
- Power consumption:** for 85 ÷ 260V AC/DC and 16V ÷ 35V AC power supply: max. 4,5 VA; 19V ÷ 50V DC power supply: max. 4,5 W
- Display:** LED, red, 4 x 9 mm high + 20-points bargraph, red-green
- Input:** current 0-20 mA or 4-20 mA, programmable, input resistance < 65 Ω (typ. 55 Ω), overload-protected, input current limited to 40 mA;
voltage 0-5 V, 1-5V, 0-10V or 2-10V, programmable, input resistance > 50 kΩ
- Displayed values range:** -999 - 9999 + decimal point
- Accuracy:** 0.1% @25°C
- Stability:** 50 ppm/°C
- Outputs:** 0, 2 or 4; relays 1A/250V AC (cosφ=1) or the OC 30mA/30VDC/100mW
- Transducer power supply output:** 24V DC +5%, -10% / max. 100 mA, stabilized, not insulated from measuring inputs
- Active current output:** operating range max. 0 - 24 mA, load resistance max. 700 Ω (option available with 2 relays, see ordering)
- Communication interface:** RS-485, 8N1 and 8N2, 1200 bit/s ÷ 115200 bit/s, Modbus RTU, not galvanically isolated from measuring inputs
- Operating temperature:** 0°C ÷ +50°C
- Storage temperature:** -10°C ÷ +70°C
- Protection class:** IP 65 (front side when an additional frame is installed); IP 40 (front side); IP 20 (case and connection clips)
- Case:** board
- Case material:** NORYL - GFN2S E1
- Case dimensions:** 48 x 96 x 100 mm
- Panel cut-out dimensions:** 43 x 90,5 mm
- Installation depth:** min. 102 mm
- Board thickness:** max. 5 mm

Ordering

SRL-49-18XX-1-X-XX1

- options:**
 - 00 : no options
 - 01 : IP 65
- power supply:**
 - 3 : 24V AC/DC
 - 4 : 85V - 260V AC/DC
- number of outputs:**
 - 0 : no output
 - 1 : REL (for 2 and 4 outputs)
 - 2 : OC (for 2 and 4 outputs)
 - 3 : 2 x REL + current output
 - 4 : 2 x OC + current output
- type of outputs:**
 - 0 : no output
 - 1 : REL (for 2 and 4 outputs)
 - 2 : OC (for 2 and 4 outputs)
 - 3 : 2 x REL + current output
 - 4 : 2 x OC + current output