

USER`S MANUAL

Profibus Interface



Multi - Display Device MA 400

Profibus Interface Option

Safety instructions (EN 61010-1)

In order to preclude any danger to the operator, the following instructions should be followed:

- a) In case any damage or malfunction is detected, take the unit out of operation without delay.
- b) Before disassembling the unit, disconnect all inputs / outputs and the supply voltage. When mounting the unit and the connections, make sure all live components are protected from being touched directly.
- c) Comply with the usual regulations and safety provisions for low and high current systems, in particular country-specific safety provisions.
- d) The maximum admissible potential existing between the pin groups as well as to the external protective conductor must not be exceeded.
- e) Make sure that the unit is property mounted before connection and power on !

In order to preclude any damage to the unit, the following items must be taken into account:

The maximum admissible potential between the pin groups must not be exceeded. This applies in particular to high voltage tests.



Refer to the instruction manual !



Warning: Hazardous live voltage !

WARNING:

There is always hazardous voltage present in certain parts during the operation of electrical equipment. Non-observance of the safety instructions can result in severe personal injury or damage to property. Only qualified personnel should work on this equipment. The successful and safe operation of this equipment is dependant on proper transport, storage, set-up, installation and careful operation and maintenance.

QUALIFIED PERSONNEL

Are personnel who are familiar with the set-up, installation, commissioning and operation of the product and have the qualifications corresponding to their activities, e.g.:

- Are trained and authorised to energise, de-energise, clear, ground and tag circuits and equipment / systems in accordance with established safety standards.
- Are trained in the proper care and use of protective equipment in accordance with established safety practices.
- Are trained in first aid.

Safety according to EN 61010-1, VDE 0411

CAT III 300 V

Pollution degree : 2; indoor use; altitude <2000 m; relative humidity <80 % up to 31 °C;
Temperature: 5 °C to 40 °C;

Profibus Interface Option

The MA400 is optionally available with profibus interface. The MA400 has all known measuring and evaluating functions without any restrictions. So the Profibus Option MA400 can be operated as a standard MA400. All currently known measuring ranges are possible; the screens are identical to those of the standard model.

The Profibus Option MA400 carries its specific instrument label. The label also shows the input/output assignments of the bus terminals.

Just connect the Profibus Option MA400 to the measuring voltages and currents and the instrument will be ready for operation as usual.

301	Version
00	Status 1
00	Status 2

The version number indicates the current software status. 301 means software status no. 1.

Further developments of the software are continuously numbered; they are downward-compatible. The status codes identify the measuring variants.

Important!

The MA400 cannot be parameterised via the profibus. Parameterisation is based on the same procedure as for instruments without profibus interface. This includes but is not limited to transformer ratios and password assignments.

The selection of the measurement values to be sent via the bus cannot be done via the bus either. For their selection, use the display menu of the Profibus Option MA400. The selection procedure is described below.

For time reasons, the number of measurement values that can be sent via the bus is limited to a maximum of 10.

Selection of measurement values

Press ENTER to acknowledge, then the menu shows the following frame:

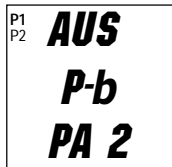

Now you are in the parameterization mode. As before, the flashing signs indicate that the associated functions are accessible.

- P1 for the selection of the display windows
- P2 for access to the parameterisation menu
- PA1 for password 1
- PA2 for password 2
- P-b for the settings at the profibus

Once the flashing P-b is confirmed by ENTER, the following display window opens:

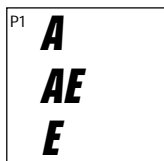

P1 flashing again.

A stands for DISPLAY. Select A and confirm by pressing the ENTER key to get a list of the previously chosen measurement values that can be sent via the profibus.

Menu item A was added to give the operator the possibility to view the values selected for bus transfer. Otherwise, direct access to the profibus would be the only way to check the values that can be sent via the bus.

AE stands for the selection of the measurement values to be transferred.

The total maximum number of measurement values available for transfer is 10. To make your selection selection, confirm AE with ENTER. The next frame shows the first possible value for transfer.

In deviation from the normal selection menu, the screen opens no windows, but displays just a sequence of individual values from a normal display window.

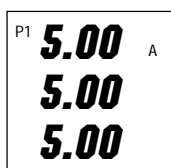

Each of the measurement values corresponds of course with the display windows. For instance, the first window offers the three phase currents, and when selecting the measurement values to be sent via the profibus, the first value appearing on the screen is the phase current for Phase L1.

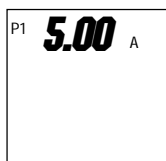

If said value is to be transferred, press ENTER to confirm, otherwise use MODE for scrolling.

The second frame is:

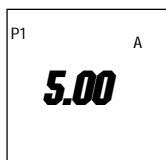

and the third frame:

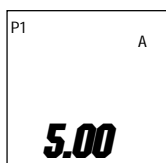

So the first display window has been split up into three individual values in the normal display mode.

A total number of 58 measurement values are available for profibus transfer. To select the appropriate measurement values, follow the description given on the following page. Press ENTER to select a value or press MODE to skip the indicated value. Then the next following measurement value will be given.

Once 10 display values have been selected, the selection mode will stop automatically and the MA400 will return to the previous display mode.

For the selection of less than 10 values, press E to end the selection. To do so, press both keys at the same time to validate your selection of measurement values to be transferred. Use MODE to select E (flashing when active) and press ENTER to quit the selection menu. So the measurement values selected for bus transfer have been defined.

The selection can be changed at any time. (Note: Access to the menu is password-protected.) There is also a possibility to visualize the selected values.

Preparation for the transfer

The following pages contain the description of each of the values. Every measurement value intended for transfer is given an identifier. Said identifier is a hexadecimal code. The coding corresponds to ASCII characters.

The actual measured variable is briefly described and the value range is indicated. The number itself is transferred as a four-byte float number.

It should be noted that always only one value at a time is available on the bus. Which value is transferred can be seen from the ID code.

Actual control of the data traffic on the bus is by a specifically generated handshake protocol. Each protocol is made up of one byte. (Both the master and the slave provide a counter as the first byte. The content of the counter is reciprocally read by the parties. If the counter status is found to have changed, the parties know that either the master has read the measurement value or that the slave is delivering valid value.

<u>Identity</u>	<u>Measured quantity</u>	<u>Designation</u>	<u>Remark/Value range</u>
21h	Current measurement	Phase L1	0.00 ... 999.999.999,99A
22h	Current measurement	Phase L2	0.00 ... 999.999.999,99A
23h	Current measurement	Phase L3	0.00 ... 999.999.999,99A
24h	Voltage	Phase L1 -> N	0.00 ... 999.999.999,99V
25h	Voltage	Phase L2 -> N	0.00 ... 999.999.999,99V
26h	Voltage	Phase L3 -> N	0.00 ... 999.999.999,99V
27h	Voltage	Phase L1 -> L2	0.00 ... 999.999.999,99V
28h	Voltage	Phase L2 -> L3	0.00 ... 999.999.999,99V
29h	Voltage	Phase L3 -> L1	0.00 ... 999.999.999,99V
2Ah	Apparent power	Phase L1	0.00 ... 999.999.999,99VA
2Bh	Apparent power	Phase L2	0.00 ... 999.999.999,99VA
2Ch	Apparent power	Phase L3	0.00 ... 999.999.999,99VA
2Dh	Effective power	Phase L1	0.00 ... 999.999.999,99W
2Eh	Effective power	Phase L2	0.00 ... 999.999.999,99W
2Fh	Effective power	Phase L3	0.00 ... 999.999.999,99W
30h	Reactive power	Phase L1	0.00 ... 999.999.999,99VAr
31h	Reactive power	Phase L2	0.00 ... 999.999.999,99VAr
32h	Reactive power	Phase L3	0.00 ... 999.999.999,99VAr
33h	Frequency	Phase L1	0,00 ... 50,0 (60,0) Hz
34h	Frequency	Phase L2	0,00 ... 50,0 (60,0) Hz
35h	Frequency	Phase L3	0,00 ... 50,0 (60,0) Hz

<u>Identity</u>	<u>Measured quantity</u>	<u>Designation</u>	<u>Remark/Value range</u>
36h	Power factor	Phase L1	0,00 ... (-)1,00 ... 0,00
37h	Power factor	Phase L2	0,00 ... (-)1,00 ... 0,00
38h	Power factor	Phase L3	0,00 ... (-)1,00 ... 0,00
39h	8min current measurement	Phase L1	Mean value 0.00 ... 999.999.999,99A
3Ah	8min current measurement	Phase L2	Mean value 0.00 ... 999.999.999,99A
3Bh	8min current measurement	Phase L3	Mean value 0.00 ... 999.999.999,99A
3Ch	8min current measurement	Phase L1	Mean value with non-return pointer 0.00 ... 999.999.999,99A
3Dh	8min current measurement	Phase L2	Mean value with non-return pointer 0.00 ... 999.999.999,99A
3Eh	8min current measurement	Phase L3	Mean value with non-return pointer 0.00 ... 999.999.999,99A
3Fh	15min current measurement	Phase L1	Mean value 0.00 ... 999.999.999,99A
40h	15min current measurement	Phase L2	Mean value 0.00 ... 999.999.999,99A
41h	15min current measurement	Phase L3	Mean value 0.00 ... 999.999.999,99A
42h	15min current measurement	Phase L1	Mean value with non-return pointer 0.00 ... 999.999.999,99A
43h	15min current measurement	Phase L2	Mean value with non-return pointer 0.00 ... 999.999.999,99A
44h	15min current measurement	Phase L3	Mean value with non-return pointer 0.00 ... 999.999.999,99A
45h	Total apparent power		0.00 ... 999.999.999,99VA
46h	Total effective power		0.00 ... 999.999.999,99W
47h	Total reactive power		0.00 ... 999.999.999,99VAr
48h	Total power factor		0,00 ... (-)1,00 ... 0,00

<u>Identity</u>	<u>Measured quantity</u>	<u>Designation</u>	<u>Remark/Value range</u>
49h	Maximum value of current	Phase L1	Instantaneous value bevor erasing 0.00 ... 999.999.999,99A
4Ah	Maximum value of current	Phase L2	Instantaneous value bevor erasing 0.00 ... 999.999.999,99A
4Bh	Maximum value of current	Phase L3	Instantaneous value bevor erasing 0.00 ... 999.999.999,99A
4Ch	Maximum value of voltage	Phase L1	Instantaneous value bevor erasing 0.00 ... 999.999.999,99V
4Dh	Maximum value of voltage	Phase L2	Instantaneous value bevor erasing 0.00 ... 999.999.999,99V
4Eh	Maximum value of voltage	Phase L3	Instantaneous value bevor erasing 0.00 ... 999.999.999,99V
4Fh	Maximum value of apparent power	Phase L1	Instantaneous value bevor erasing 0.00 ... 999.999.999,99VA
50h	Maximum value of apparent power	Phase L2	Instantaneous value bevor erasing 0.00 ... 999.999.999,99VA
51h	Maximum value of apparent power	Phase L3	Instantaneous value bevor erasing 0.00 ... 999.999.999,99VA
52h	Maximum value of effective power	Phase L1	Instantaneous value bevor erasing 0.00 ... 999.999.999,99W
53h	Maximum value of effective power	Phase L2	Instantaneous value bevor erasing 0.00 ... 999.999.999,99W
54h	Maximum value of effective power	Phase L3	Instantaneous value bevor erasing 0.00 ... 999.999.999,99W
55h	Maximum value of reactive power	Phase L1	Instantaneous value bevor erasing 0.00 ... 999.999.999,99VAr
56h	Maximum value of reactive power	Phase L2	Instantaneous value bevor erasing 0.00 ... 999.999.999,99VAr
57h	Maximum value of reactive power	Phase L3	Instantaneous value bevor erasing 0.00 ... 999.999.999,99VAr
58h	Maximum value of total apparent power		0.00 ... 999.999.999,99VA
59h	Maximum value of total effective power		0.00 ... 999.999.999,99W
5Ah	Maximum value of total reactive power		0.00 ... 999.999.999,99VAr

Data transfer via the profibus

A GSD file is provided. Upon delivery, the MA400 has the address 126.

Data protocol

The master is to send a package of 4 bytes. Only the first byte has a meaning for handshake operation. The first byte can be regarded as a counter. If the value increases by 1, the receiving party connected to the bus knows that the master has, for instance, received the data correctly. With regard to MA400, this means that the master has received the first measurement value, which consists of a code byte and a measured value.

Byte 1 Counter for handshake
Byte 2 No meaning
Byte 3 No meaning
Byte 4 No meaning

The MA400 receives the new counter status and can then in turn deliver new data. The MA400 sends 8 bytes in total. Again, the first byte forms a counter. Once the MA400 has received the new counter status from the master, the MA400 increases the counter by 1 thus showing that a new value is available on the bus. This counter is assigned to the first byte. The second byte contains the code for the transferred value as shown in the table of the previous pages. The next four bytes contain the actual measurement value in the float format. The 7th byte is the end code (0D). The 8th byte has no meaning.

Byte 1 Counter for handshake
Byte 2 Code byte for measurement value
Byte 3 Measurement value MSB
Byte 4 Measurement value
Byte 5 Measurement value
Byte 6 Measurement value LSB
Byte 7 End code 0D
Byte 8 No meaning

The delivery includes a floppy disk with the required GSD file
MA400_V1.GSD

Pin assignment

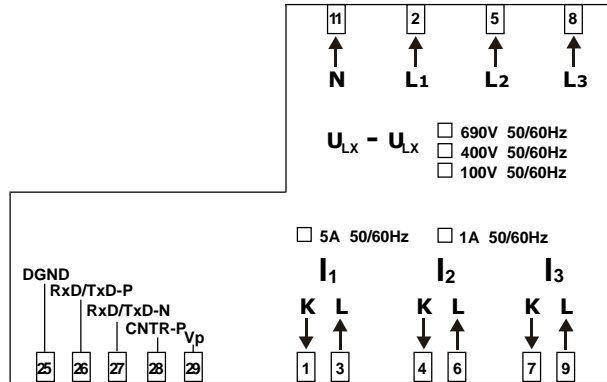

Rating plate

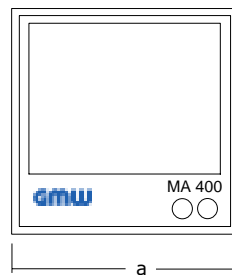
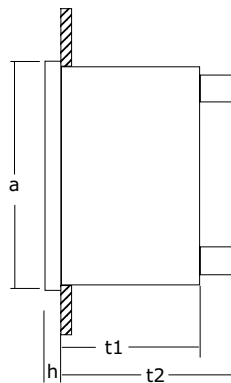
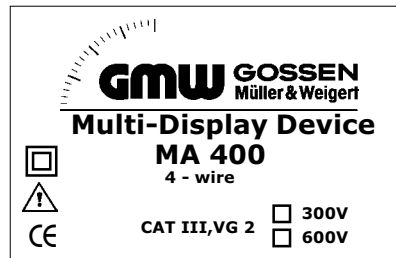

Mounting dimension

h	5 mm
t1	43,5 mm
t2	58 mm

GOSSEN Müller & Weigert

Kleinreuther Weg 88

D-90408 Nürnberg

Tel.: 0911/3502-0 Fax: 0911/3502-307

E-mail: info@g-mw.de <http://www.g-mw.de>



Metrix Electronics Limited

Minchens Court, Minchens Lane,
Bramley, RG26 5BH, U.K.

Tel:+44 (0)845 034 3234, Fax:+44 (0)845 034 3233

E-mail: sales@metrix-electronics.com

Web: www.metrix-electronics.com

