

USER`S MANUAL
Version 6.10.12 or higher



Thermal Graphics Printers
IPP 144 - 40 G
IPP 144 - 40 GE

Paper Reroll Mechanism
IPP - AW

Table of Contents

	page		page
I. IPP 144 - 40 G / IPP 144 - 40 GE	3 - 56		
1. General features	3 - 5	8. Appendix	36 - 56
2. Technical data	6 - 9	8.1. Menu program - complete Selection	36 - 37
2.1. Basic Version	6 - 8	8.2. Character sets	38 - 40
2.2. Version E	9	8.3. Details of printer control Commands	41 - 48
3. Design and installation	10 - 11	8.3.1. Short view of control commands	41
4. Connection	11 - 17	8.3.2. Print character commands	41 - 42
4.1. Pin assignment	11 - 13	8.3.3. Bitmap image commands	43 - 45
4.2. Interface selection	14	8.3.4. Line feed commands	45 - 46
4.3. Connecting diagram serial	15 - 17	8.3.5. Barcode commands	47 - 48
5. Operation	18 - 23	8.3.6. Print position commands	48
5.1. Operating controls	18 - 19	8.4. Connection examples for GMW instruments	49 - 50
5.2. Replacing the paper roll	20	8.4.1. Connection with DPM / MF	49
5.3. Menu program	21 - 23	8.4.2. Coupling with DAA	50
6. Adjustments	24 - 29	8.5. Examples for automatic text insert Mode	51
6.1. General settings	24 - 25	II. Paper Reroll Mechanism IPP - AW	52 - 55
6.2. Serial interfaces settings	25 - 26	1. General information Design / Installation	53
6.3. Date / time	26 - 28	2. Technical data	54
6.4. Date / time Output	28 - 29	3. Operation	55
7. Functional description	30 - 35	III. Accessories	56
7.1. Start printing	30		
7.2. Addressing	30 - 31		
7.3. Handshakes messages	31 - 33		
7.4. Version E (IPP 144-40 GE)	33 - 35		
7.4.1. Texts Entry	33 - 34		
7.4.2. Texts output	35		

Index

	page		page
Accessories	56	Operating controls, general	18
Addressing	26, 30	Paper	6
Addressing & protocol / text	31	Paper reroll mechanism	57
Basic version	5	Parameters, changing	22, 23
Baudrate	25	Parameters, printing the current	21
Barcode Commands	47	Parity	25
Bitmap image Commands	43	Pin assignment current loop	16
Character set	24, 38	Pin assignment - Interface I	15
Connection diagrams	11	Pin assignment - Interface II	17
Connection Examples	59	Print character commands	41
Control characters	38	Print control commands	40
Data format - serial	25	Print format	24
Date / time - output via Interface II	28	Print interval - serial	32
Date / time - setting	26	Print interval - setting	24
End of paper indication	18	Print mechanism	6
Environmental conditions	7	Protocol - serial	29
Enhanced version (E - version)	5	Replacing the paper roll	20
Handshake serial - RTS / DTR	31	Snap lock	18
Handshake serial - XON / XOFF	32	Software version	8
Headline data & time	29	Start printing	30
Input buffer	7	Technical data	6
Installation	10	Text adding, overwrite	33
Interface selection	14	Text call with measured data, serial	34
Key LINE FEED / ENTER	18	Text - deleting	33
Key lock	19	Text entry	33
Key MENU / SELECT	18	Text entry - block	34
KEY RESET	19	Text entry - wildcards	28
Line Feed Commands	45	Text output	35
Line width (characters per line)	24	Voltage supply	7
Mechanical data	8	Wildcards for measure value	34
Menu program - complete selection	36	Windows programming software	5
Menu program - entry	21	Write protection	19
Menu program - quitting	22		
Model types	4		

I. IPP 144 - 40 G / IPP 144 - 40 GE

1. General features

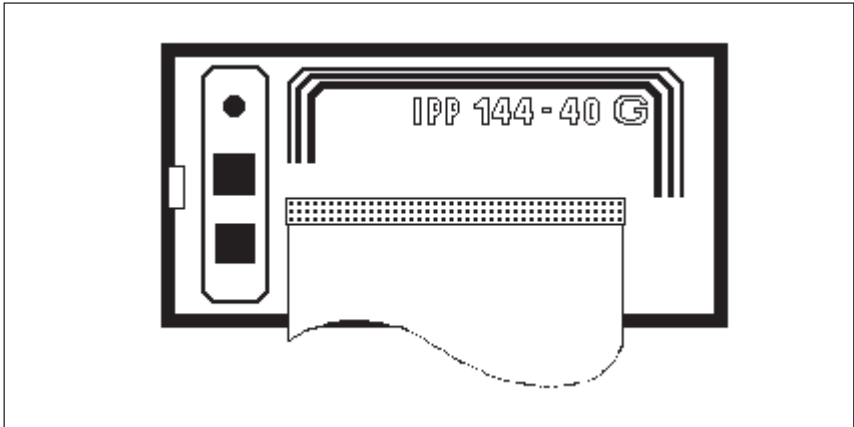

The Thermal Graphics Printer IPP 144-40 G (Industrial Process Printer) is a device designed for outputting text, data and graphics, i.e. measured value, machine and process states, error messages, production data, etc.

Two application examples:

- If connected to a digital voltmeter, the IPP 144-40 G records the measuring values (with date/time for the E version).
- Its integrated interface allow the use of the IPP 144-40 G as a peripheral for all PLCs (RS 232 C; RS 422; RS 485; USB; Profibus DP).

The Thermal Graphics Printer is a DIN size panel mounting unit which is able to print line widths of up to 48 characters per line. The 14m paper roll (commercial grade document proof thermal paper) is located inside the housing and can be easily replaced by means of a swivel type front panel. An end of paper indicator lights up if the printer runs out of paper.

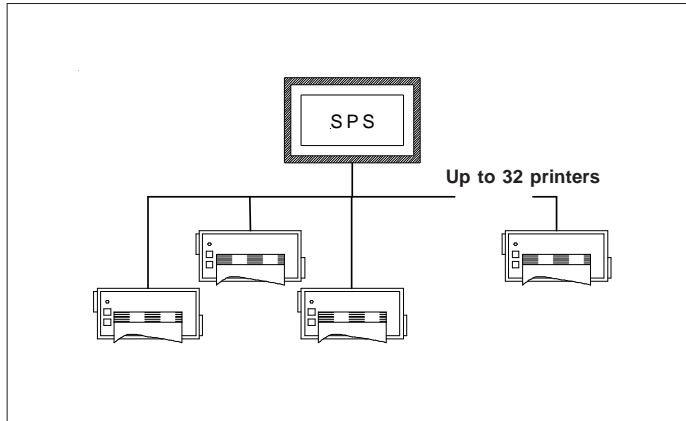

Each printer is addressable, which allows the connection of up to 31 devices to one sender device via a data line at the RS 485 interface, e.g. to a PLC.

Review of the model types

There are two versions of the printer: The basic version IPP 144-40 G with the Interface I and the enhanced version IPP 144-40 GE with the Interfaces I and II.

There are three options for the voltage supply: 12V DC (10V...19V DC) or 24V DC (19V...36V DC) or 110V/230V AC (switch-mode power supply: 85V...265V AC). Interface

There are four options for the Interface II: RS 232 C, RS 485, ProfiBus or USB

Model	Supply Voltage			Interface I	Interface II
IPP 144-40 G	12V DC	24V DC	110/230V AC	Yes	None
IPP 144-40 GE 232	12V DC	24V DC	110/230V AC	Yes	RS 232 C
IPP 144-40 GE 485	12V DC	24V DC	110/230V AC	Yes	RS 485
IPP 144-40 GE PB	12V DC	24V DC	110/230V AC	Yes	ProfiBus
IPP 144-40 GE USB	12V DC	24V DC	110/230V AC	Yes	USB

The connector for the Interface II of RS 232 C, RS 485 and ProfiBus is a 9 pin D-Sub-socket. It is possible to change this Interface card in the factory. The interface option USB has a special USB-B-socket. It is not possible to change this interface card with the other cards. Special adapter cables and converters are used in this situation.

**Basic Version
IPP 144-40 G** The basic version IPP 144-40 G provides one serial interface capable of receiving only. Return (handshake) messages to the sender are sent via hardware line. Texts and measuring values to be printed must be transmitted from the sender device since the basic version does not have an internal text memory. It is possible to print with the basic version bitmap image and barcodes. The bitmap image files and the barcode files are generated with printer control commands in a terminal emulation program. These files are transmitted by Interface I to the printer.

**Enhanced
Version
IPP 144-40 GE** The enhanced version IPP 144 - 40 GE provides a second, bi-directional serial interface capable of outputting return messages under program control in compliance with a protocol. In addition, this model includes a text memory capable of storing up to 15 texts which are called by specifying the corresponding text number. Moreover, date and time may be printed with texts and data. It is not possible for the user to upgrade the basic version to the enhanced version; as this is a different factory version.

**Print graphics
directly from
Windows®** It is possible to print graphics, such as bmp-, jpg- or tif, directly from Windows® programs. Use a 24-pin type Windows® **printer**. The following configurations have been verified: Epson Combatible 24-pin and Epson LQ560.

**Microsoft
Windows®
compatible
programming
software** A programming software for use with Microsoft Windows® operating systems has been developed. This software provides functions to program the GE text memory, transfer user defined fonts or symbols and set the printer configuration parameters. Also this software package includes actual Windows® printer drivers. The software will be shipped on CD-ROM.

2. Technical data

2.1. Basic version

Print mechanism

Type of printing	Fixed head thermal line
Character representation	576 dots/Line, 8 dots/mm
Print speed approx.	15 line/s (standard text mode)
Character/line	48 characters 40 characters 24 characters 20 characters
Character height	2.5 mm at 48(40) characters 5 mm at 24 (20)characters
Character sets	ASC II, german, french, danish, norwegian, swedish / finnish, spanish, english, cyrillic
Service life	min. 10x10 ⁶ Impulse or 50 km

Paper

Type	commercial grade, document proof thermal paper
Width	80 mm (+0 / -1 mm)
Length	approx. 14 m (approx. 4.600 line up to 48 characters per line)
Max. outer roll diameter	40 mm
Min. inner roll diameter	11,5 mm
Temperature	standard paper: 0 °C to 60 °C

Input buffer	Serial	8 kB
	Serial Interface I	
	Type	RS 232 C; RS 422; RS 485 or Current loop
	Baudrate	110; 150; 300; 600; 1200; 2400; 4800; 9600; 19200; 38400
	Data format	7 bit ¹⁾ / 8 bit
	Parity bit	even, odd, mark, space, no
Voltage supply	Safety	acc. to EN 61010-1 CAT III > 150 V ≤ 300 V pollution degree 2
	DC	10 V ... 19 V ca. 20 VA ²⁾
		19 V ... 36 V ca. 18 VA ²⁾
AC	85 V ... 265 V , 45 - 65 Hz, ca. 15 W switch-mode power supply	
Ambient conditions	Temperature ranges:	
	Storage	-20 °C to +60 °C
	Operating	0 °C to +45 °C
	Climate	relative humidity < 80 % up to 31 °C
Standards	Protection type	acc. to EN 60529/VDE 0470
	Housing	IP 50
	Terminals	IP 00
	Insulation group	C acc. to VDE 0110
	Mech. strength	acc. to IEC 1010
	EMC	
	Emission	EN 55011, Class A EN55022, Class B
	Susceptibility	EN 61000-4-2 B EN 61000-4-3 A EN 61000-4-4 B



¹⁾ With 7 bit no parity, the sender must be set to 2 stop bits.

²⁾ Starting current approx. 3.5 A (10 V ... 19 V) or approx. 1.2 A (19 V ... 36 V).

This value can be used to rate the external fuse.

Connections

Voltage supply connector	Screw type/terminals
Wire diameters	fixed: 0,2 to 4 mm ² flexible: 0,2 to 2,5 mm ² AWG: 24 to 12
Interface I	9 pin D-Sub socket
Interface II	9 pin D-Sub socket or USB-B socket
Connection for paper re-roll mechanism	4pin MASCON, MLAS
Connection for Alarm relay output	Screw type/terminal fixed: 0,2 to 4 mm ² flexible: 0,2 to 2,5 mm ² AWG: 24 to 12 normally open 50 V AC, 2 A 30 V DC, 2 A

Miscellaneous

Dimensions (W x H x D)	144 x 72 x 159 mm
Switchboard mounting	screws against rear side of switchboard
Internal fuse (on power supply board)	12V DC : T 3,15 A 24V DC : T 2 A 110V - 230V AC : T 2 A

**This operating manual applies to software version
6.10.12 and higher**

2.2. Version E

Serial Interface II

Type	RS 232 C or RS 485 ¹⁾ Profibus or USB
Baudrate	110; 150; 300; 600; 1200; 2400; 4800; 9600; 19200; 38400
Data format	7 bit ²⁾ / 8 bit
Parity bit	even, odd, mark, space, no

Text entry for texts to be stored

separate configuration
by Interface II

Text memory

Type	flash memory
Memory size	600 Byte $\hat{=}$ 15 texts

Internal clock

Type	CMOS, battery buffered ³⁾
Accuracy	± 10 ppm $\hat{=}$ 0,8 sec / day

- 1) Please specify when ordering; if nothing is specified, RS 232 C is supplied.
- 2) With 7 bit no parity, the sender must be set to 2 stop bits .
- 3) Lithium battery: 3 V
type: VARTA CR 2/3 AA Typ 6237
PANASONIC BR 2/3A 1 P



Warning!

This product contains a Lithium battery which must not be cut open, incinerated, exposed to temperature above +60 °C or recharged.
Dispose of in accordance with national regulations.

3. Design and installation

Design

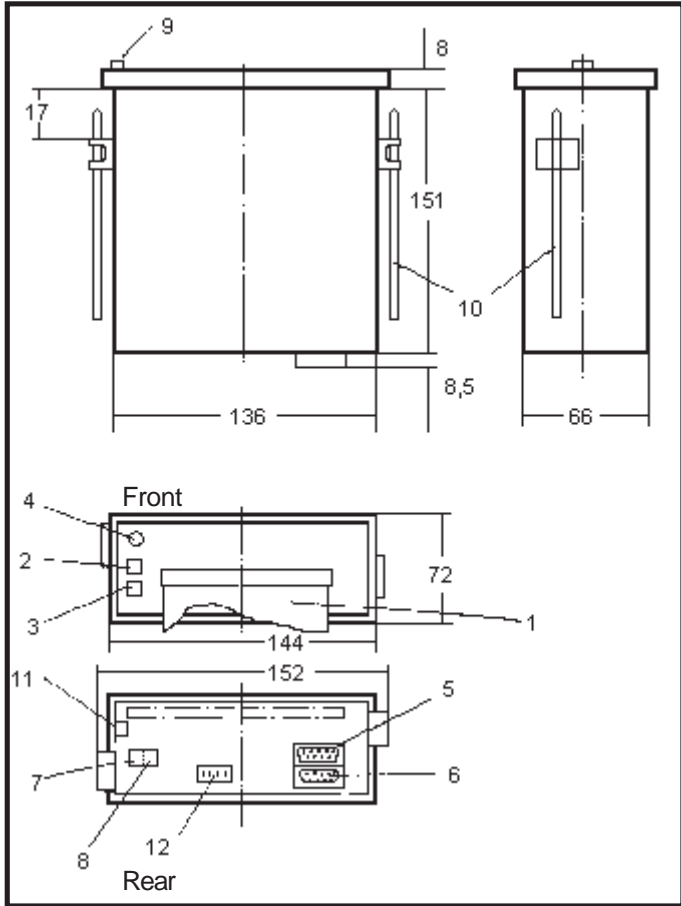

- | | | | |
|---|---------------------------------|----|---|
| 1 | Paper and cutting edge | 8 | alarm contact |
| 2 | Key: LINE / FEED / Enter | | (paper end only version E) |
| 3 | Key: MENU / Select | 9 | Snap lock |
| 4 | Alarm LED (paper end indicator) | 10 | Mounting screws |
| 5 | Serial interface | 11 | Protective conductor connection. Must be connected to ground. |
| | Interface II (only version E) | | |
| 6 | Serial Interface I | 12 | Connection / paper reroll mechanism IPP-AW |
| 7 | Voltage supply | | |



Make sure that the unit is properly mounted before connection and power on.

Installation

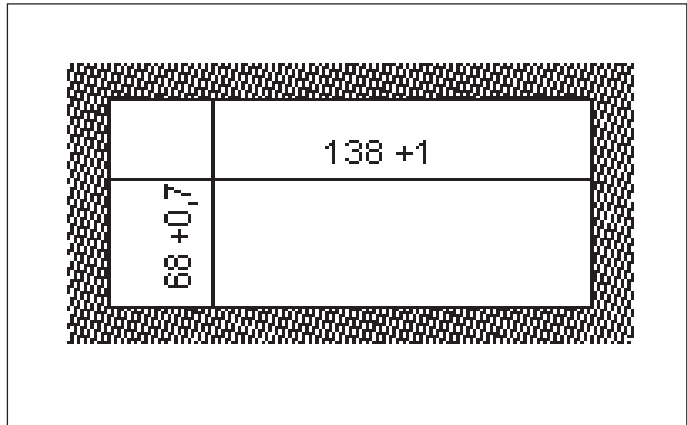

The IPP 144 - 40 G fits into a DIN standard panel cut out. It is inserted into the switchboard opening from the front side and is fixed against the switchboard rear using mounting screws. The switchboard thickness must not exceed 12 mm.

4. Connection

4.1. Pin assignments

Pin assignment

WARNING: This device must be grounded -ACHTUNG: Dieses Gerät muss geerdet werden! Serien Nr.:
 Opt.: Serial No.:
 EN 61010-1:2001 CAT III No.de serie

IPP 144 - 40 G  85 V...265 V AC; 45...60Hz; 15W
 19 V...36 V DC; 18 VA
 10 V...19 V DC; 20 VA

 Lithium battery inside (VERSION E)

Interface II

RS 232 C
 RS 485
 Profi Bus
 USB

Interface I

5 0 Sig GND
 9 0 TXD
 0 0
 0 0 RTS
 0 0 DTR
 0 0 RXD
 0 0 GND

IPP-AW

5 0 RXD(-)
 9 0 Sig GND
 0 0 CLA
 0 0 +5VIs
 0 0 RXD(+)
 0 0 GND

Interface I

5 0
 9 0 RTS
 0 0
 0 0 DTR
 0 0 TXD

 Alarm
 + L1
 - N
 T

Connect the unit as shown in the connection diagrams.
 Observe all national safety regulations, especially for the power supply connections.

WARNING: This device must be grounded .



Serial Interface I

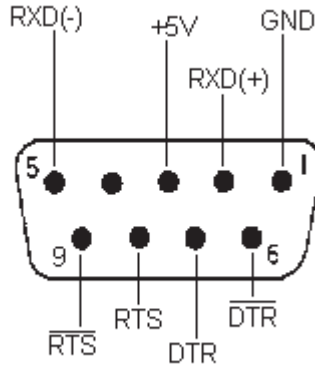

Pin	Signal	
1	GND	Ground (shield)
2	RXD (+)	Receive data
3	+5 V	Output +5 V / 20 mA
4	n.c.	
5	RXD (-)	Signal ground
6	$\overline{\text{DTR}}$	Open collector; active if DTR is +8 V
7	DTR	(Data Terminal Ready) +8 V: ready to receive -7 V: not ready to receive
8	RTS	(Request To Send) +8 V: ready to receive -7 V: not ready to receive (text buffer is full)
9	$\overline{\text{RTS}}$	Open Collector; active if RTS is +8 V

The serial Interface I has been designed to allow the implementation of all widely used interfaces: RS 232 C; RS 422; RS 485 and Current loop.
See chapter 4.3.: Connecting diagram

**Serial
Interface II
(only
IPP 144 -40 GE)**

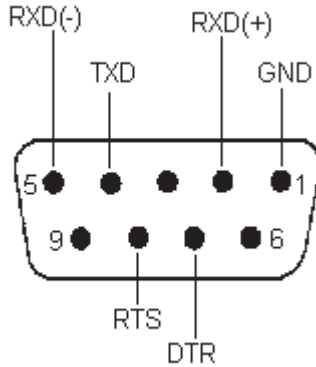

**Prints
barcode**

Pin	Signal	
1	GND	Ground (shield)
2	RXD (+)	Receive data
3	n.c.	
4	TXD	Transmit data
5	RXD (-)	Signal ground
6	n.c.	
7	DTR	(Data Terminal Ready) +8 V: ready to receive -7 V: not ready to receive
8	RTS	(Request To Send) +8 V: ready to receive -7 V: not ready to receive
9	n.c.	

This interface can either be operated under hardware handshake (DTR, RTS) or software handshake (XON / XOFF - Protocol). This does not require special settings.

See chapter 4.3.: Connecting diagram

4.2. Interface selection (Interface I)



Slide snap lock to the right hand side, swivel front door out. Now you can see the switch S 101 on the printed circuit board.

- For RS 232 C, RS 422 and RS 485 set switch S 101 to the **right** hand side.
- For Current loop, set switch S 101 to the **left** hand side.

IMPORTANT:

This switching only applies to Interface I.

If the printer is connected to the sender device (e.g. to a PLC) the interface parameters must be matched to those at the sender device. See chapter 6.2. which describes the setting of baudrate, data format, stop bit and parity bit.

4.3. Connecting diagram

Interface I

Set slider switch S 101 to the right hand side !

(see „Interface selection“ 4.2.)

RS 232 C

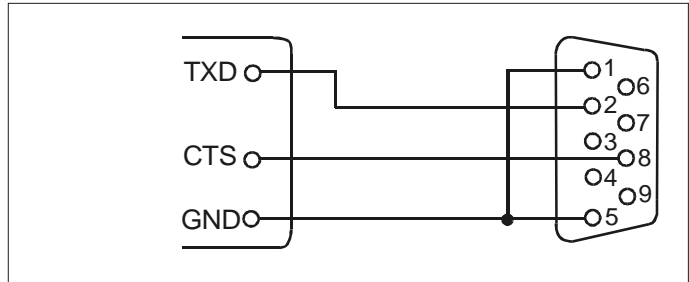

RS 422

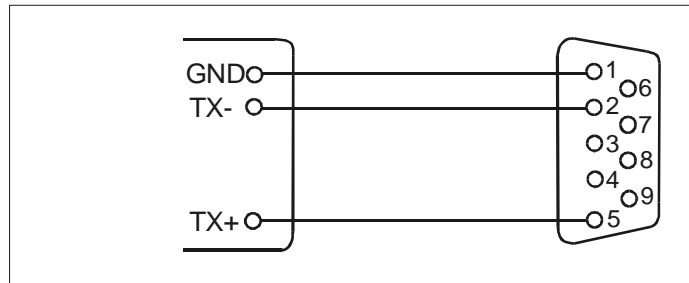

RS 485

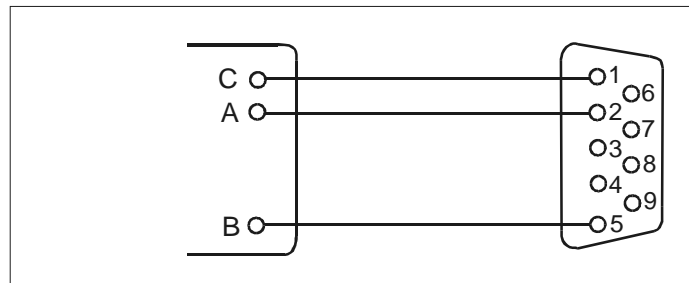

Sender/receiver

IPP 144

Current loop

Set slider switch S 101 to the left hand side !
(see „Interface selection“ 4.2.)

Sender **active**,
IPP 144 - 40 G
passive

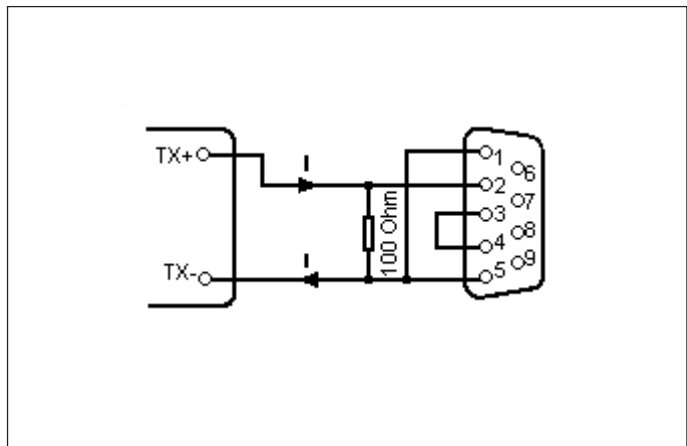

Sender active

IPP 144-40G passive

Sender passive

IPP 144-40G active

Sender **passive**
IPP 144 - 40 G
active

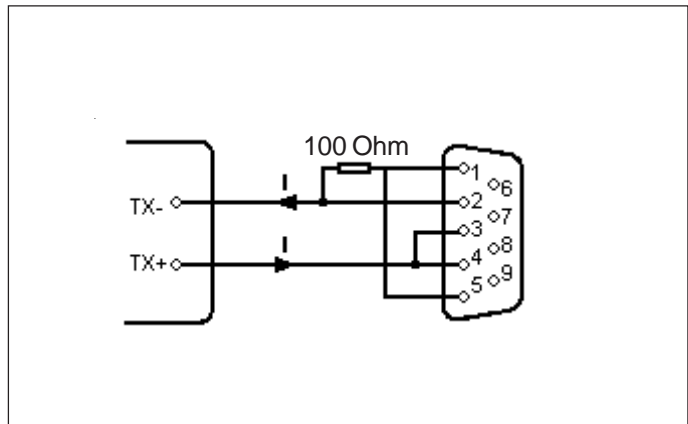

„I“ identifies the direction in which the current flows
(20 mA).

Interface II

RS 232 C

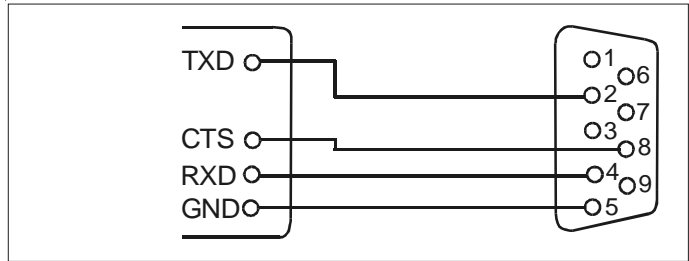

RS 485 (Option)

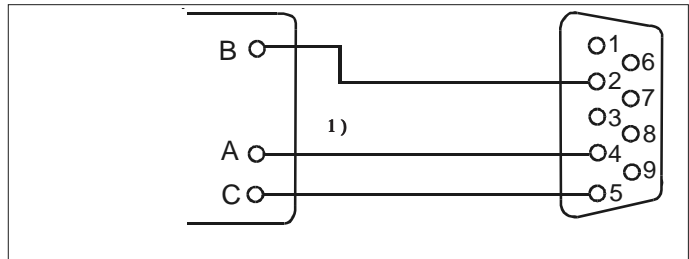

Profibus (Option)

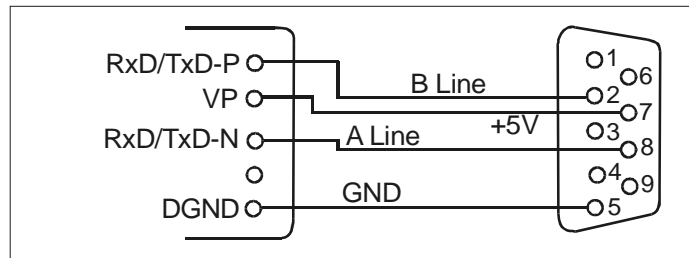

transmitter / receiver

IPP 144-40 GE

Explanation concerning the signal names under RS 485.

- 1) The names A, B, C correspond to the EIA 485 - Standard:
inactive or logical „1“; A > B
logical „0“: B > A

If an interface does not comply with that standard, the connections of A and B must be interchanged.

USB (Option)

Standard USB chassis socket type B



- pin 1 +5V
- pin 2 USBDM
- pin 3 USBDP
- pin 4 GND

5. Operation

5.1. Operating controls

The numbering of the operating controls refers to the diagrams in chapter 3.

LED „Alarm“ (4)

The ALARM LED has two functions:

1. To indicate „end of paper“
2. To indicate that the front door is open

Examples:

1. The front door is closed.

If this LED is lit, the printer has run out of paper. Insert a new paper roll; see section 5.2. „Replacing the Paper Roll“.

The front press-button switches (LINE FEED & MENU keys) are deactivated.

2. The front door is open.

The LED is lit. Printing may continue until the input buffer is empty, and then the data transmission goes to standby.

3. The front door is open and the printer has run out of paper.

The LED lit. The printer stops printing and the front press-button switches are deactivated.

After replacing the paper roll the front press-button switches are active. The ALARM LED remains ON until the front door is closed. The printer can start working.

LINE FEED / ENTER (2)

This key has two functions:

- LINE FEED:
During operation the key is used for manual paper feed.
- In the menu program it is used to accept and save the parameters selected via „Select“.

MENU / SELECT (3)

This key has two functions:

- MENU:
When this key is pressed during operation continuously for more than 3 seconds, the printer switches into programming mode. In this mode device parameters can be modified or printed out.
- Select:
Within the menu program it is used for selecting the device parameters.

Paper cutting edge (1) In order to tear off the paper, pull the paper quickly sideways and up.

Snap lock (9) Push this to the right hand side to open the front panel in order to be able to replace the paper roll or to set the slider switch S 101 which is used to set the desired interface (see chapter 4.2. „Interface selection“) or to set the RESET switch S 102.

Locking the menu / Select key

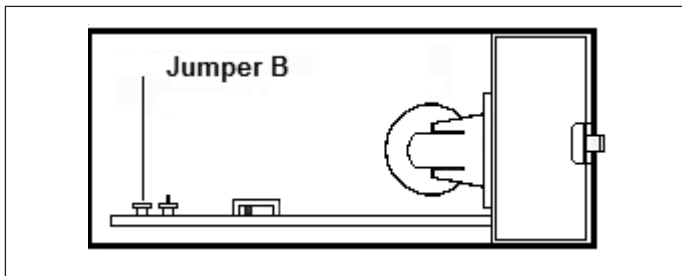

If the jumper B is connected, the „MENU / SELECT“ key is locked; parameters can neither be printed nor modified.

In order to print or modify parameters:
remove **jumper B** !

RESET -key The key S102 resets the printer to the standby mode. The menu parameters will not to be changed.

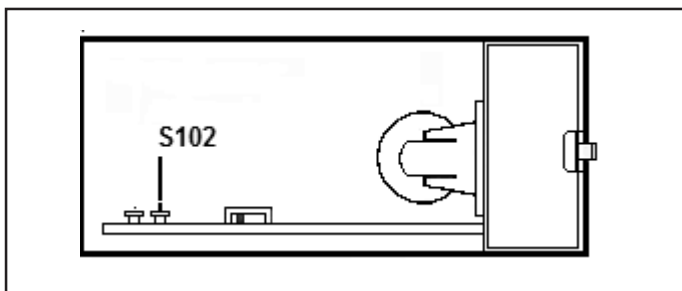

5.2. Replacing the paper roll

Proceed as described below:

1. For devices with a.c. powersupply be very careul.



Warning: Dangerous voltage

is accessible if replacing the paper roll after opening of the front panel !

2. Push the snap lock to the right hand side and open the front panel.
3. Tilt the wire frame upwards and remove the old paper roll.
4. Insert new paper roll and make sure that it rotates clockwise during printing (see figure 1).
5. Cut a straight edge at the start of the roll using scissors (figure 2) and fold approx. 2cm of this edge opposite to the roll direction. Fold this section until it is about 90 degrees to the rest of the paper (figure 3). Insert the folded start of the roll into the paper feed slot as shown in figure 1.
6. Press the „LINE FEED / ENTER“ key until the paper appears at paper cutting edge.
7. If you have fed too much paper, carefully rewind the roll. Push the wire frame back over the roll.
8. Close the front panel (snap lock must lock). The Alarm LED extinguishes and the printer is ready.

ACHTUNG !
PAPIER RICHTIG EINLEGEN
POSITION CAREFULLY THE
PAPER
ATTENTION A' LA
MISE EN PLACE DU PAPER !

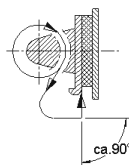

Figure 1

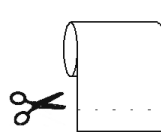

Figure 2

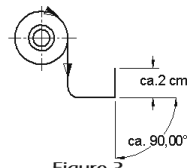

Figure 3

5.3. Menu program

All functions of the IPP 1444 are set via menu program using the „ENTER“ and „SELECT“ keys and are saved when the user quits the program.

From then the IPP 144 automatically uses these parameters.

The print format for the printout of the parameters is always NORMAL with 48 character per line, so that the parameters can be read easily by the user.

The various settings are explained in chapter 6.

Entering the menu program

Press the „MENU / SELECT“ key for approx.

3 seconds.

The IPP 144 reacts by printing

„ACTUAL PARAMETERS ? PRESS „ENTER“

Print current parameters

Press the „ENTER“ key.

The IPP 144 prints the currently set parameters.

The last line that is printed out says:

„CHANGE PARAMETERS ?“

The menu program „Change Parameters“

By pressing „ENTER“ and „SELECT“ simultaneously for approx. 4 seconds; the IPP 144 prints out the first parameter that can be modified.
(see changing parameters)

The menu program „Change Parameters“ can be called in one of two ways:

- **Without** prior printing of the current parameters:
Press both keys after the printout „ACTUAL PARAMETERS ? ...“.
- **With** prior printing of the current parameters:
Press both keys after printout „CHANGE PARAMETERS ?“.

Quitting the menu program

The program is terminated by simultaneously pressing „ENTER“ and „SELECT“ following the printout

„END“.
All modified functions are saved.

If there are no keys pressed over a period of approximately 2 minutes, the program is terminated automatically and any **modifications** made **are not saved**.

Changing parameters

The IPP 144 prints one of the changeable parameters:

Press „ENTER“ to accept the parameter and to move to the next one.

Press „SELECT“ to display the next parameter option.

Example:

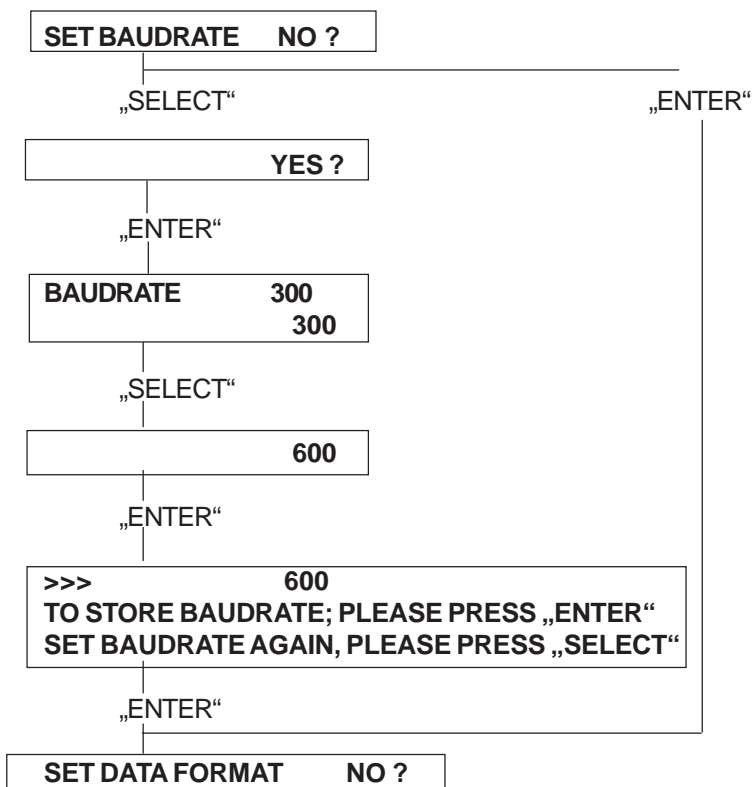

Explanation

1: Baudrate 600 (Baud)
is saved

In case

2: Baudrate 300 (Baud)
is saved

6. Adjustment

6.1. General settings

The various settings and device parameters are selected and set via the menu program (see chapter 5.3.).

The appendix contains a summary.

PRINT FORMAT

- **NORMAL:** The printout can be read during printing. The last line that was printed out is on top.
- **INVERSE:** The printout is made top down, the last print line is at the bottom. In this case the printout is in the proper chronological order after the paper has been torn off.

Print formats can be switched via the serial interface (see appendix 8.2. „additional control characters“), if the input buffer is empty!

PRINT STRENGTH

The print strength can be set in 4 steps.

- LEVEL 1 minimum print strength
- LEVEL 2
- LEVEL 3
- LEVEL 4 maximum print strength

The print strength changes immediately after the selection has been made.

CHARACTER / LINE 48: 48 characters per line = standard character width
40: 40 characters per line
24: 24 characters per line
20: 20 characters per line

The character width can be switched via the serial interface (at the beginning of a line and only if the input buffer is empty).

CHARACTER SET

Available character sets are:
ASCII, GERMAN, FRENCH, SWEDISH/FINNISH (S/SF),
DANISH, NORWEGIAN, SPANISH, UK (English) and
CYRILLIC.

Character sets see appendix 8.2. „Character Sets“ !

INTERFACE

- SERIAL
- USB - Serial IF2 (version E only)

This sets the printer for data transmission via serial interface or USB-interface.

PRINT INTERVAL

The printing of measuring values can be carried out under internal timer control.

Setting range: 10 s ... 24 h in steps of 10 s.

The interval starts, when the last received line was printed.

For more information see chapter 7.3. „Handshake Messages“ !

MODE

There are 2 operating modes:

- ONLINE: The device is ready to receive.
- OFFLINE: The device is not ready to receive.

6.2. Serial interface settings

BAUDRATE

There are ten baud rates available:

110; 150; 300; 600; 1200; 2400; 4800; 9600;
19200 and 38400 Baud.

DATA FORMAT

There are two formats available:

7-bit or 8-bit - transmission,
1 start bit / ... / parity / 1 stop bit.

Attention:

With 7 bit no parity, the sender must be set to 2 stop bits!

PARITY

There are five options available:

Even; Odd; Mark; Space; No parity.
There is no check made.

PRINTER ADDRESS

Each printer IPP 144 - 40 G / IPP 144 - 40 GE can be addressed. This allows the transmission of data to several printers via one data line.

Up to 31 printers may be called from one sender (e.g. a PLC). The respective address is set in the menu program.

For more information see chapter 7.2. „Addressing“ !

6.3. Date / time (only E-version)

Setting the time

Date and time are factory set. In order to modify these values the menu program must be called and the following message must be displayed:

SET TIME	NO ?
	Minute
	Hour Second
SET TIME	12 : 31 : 33
	_2 : 31 : 00

If the time is modified, the seconds are automatically set to zero. Instructions on how to change values, see the description of input the date on the next page.

If the time has been entered and „Enter“ has been pressed, the following is displayed:

>>>	22 : 31 : 00
TO STORE TIME; PLEASE PRESS „ENTER“	
SET TIME AGAIN; PLEASE PRESS „SELECT“	

If time has been entered correctly, press „Enter“. If the time has been entered incorrectly, repeat the input by pressing „Select“.

Date entry

The date is set like the time. After the current time has been printed, the following line appears:

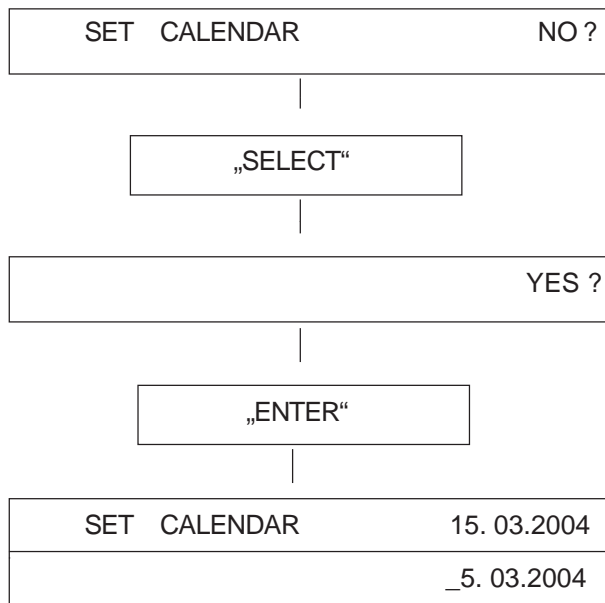

The printed cursor to the left of the 5 indicates that this position can be modified; in our example this is the decade of the day value. The „Select“ key is used to print the possible values successively; in our example this is 0, 1, 2 and 3. To accept the value press „Enter“; the cursor jumps to the next position to the right ... etc.



Finally the currently set date is printed out again.

Note:

Incorrect entries, e.g. day 33 of a month, will not be accepted by the printer. Instead, it starts over at the base value 00.

**Set Summer
Winter Time
Mode**

Set one hour plus or minus for Summer/ Winter Time Mode following is displayed:

CHANGE TIME W<->S	NO ?
-------------------	------

If „YES“ is selected, the follow selections are displayed:

„W ---> S (+1 h)“ (winter time)

„S ---> W (- 1 h)“ (summer time)

After setting time the current time will be printed. Press „ENTER“ to store time or press „SELECT“ to set time again.

6.4. Date / time output (E - Version)

Output

Date and time may be transmitted via the serial Interface II

Request:

< Ctrl W > < CR >

Addressed:

<Ctrl E> Adr. <Ctrl E> <Ctrl W> <CR> <Ctrl D>

The IPP 144 returns date / time in the format:

< CR > < LF >

15.03.2004 17:03:24

< CR > < LF >

During the transmission, no data can be received (RTS = LOW).

Serial protocol

The IPP 144 is capable of printing date and time together with measured values or text as a protocol. In this case, date and time precede the printout.

There are two options available:
Each transmission is preceded with the date/time (always).
Date and time only precede the transmission if control command has been received.

this optional feature is selected in the menu program under:

Print date/time „always“

PRINT DATE / TIME	HEADLINE
-------------------	----------

For several messages in a row (i.e. the IPP 144 is still printing), the date & time is printed once only at the beginning of the transmission.

e.g.:
15.03.2004 16:57:30
Oil temperature 367,5 °C
Oil pressure o.k.
Boiler 1

Pause >

15.03.20004 16:58:59
Boiler 2 still active
Temperature 258,6 °C

Print date/time with a received control command

PRINT DATE / TIME	CTRL „^ „
-------------------	-----------

Date and time only precede the transmission if the character <Ctrl ^> has been received.

7. Functional description

7.1. Start Printing

To start the printing, the IPP 144-40 G expects only the character <CR> (Carriage return, Enter).

Note:

<LF> alone has by itself **no** effect combined with other control characters (calling text, send clock, start print interval -see following sections).

If characters are transmitted **without** the print triggering character, the IPP 144 - 40 G prints them after approx. 3 seconds.

Other widely used print trigger characters such as <FF> Form feed are ignored.

7.2. Addressing

Each IPP 144 - 40 G / IPP 144 - 40 GE printer is addressable. Thus, several printers can be supplied with different data via one data line.

Up to 31 printers can be connected to one sender device (e.g. a PLC). The respective address is set in the menu program.

Note:

- Standard interface RS 232 only permits 1 sender / 1 receiver. Do not connect more than 4 IPP's as receivers.
- Only interface RS 485 allows up to 32 receivers !

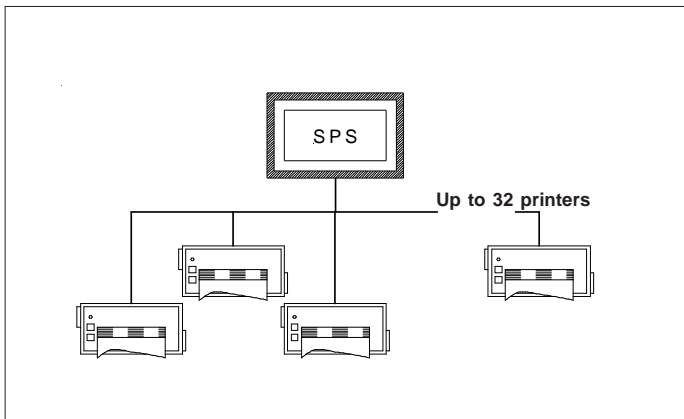

Address / ASCII character assignment example:

Address	Address in Protocol (HEX)	corresponding ASCII - character
0	-	without addressing
1	31	1
.	.	.
.	.	.
.	.	.
30	4 E	N
31	4 F	O

Protocol & Text

The addressing protocol is:

<Ctrl E> address <Ctrl E> characters ...<CR> <Ctrl D> A text of more than one line is possible.
--

(<Ctrl E>, <Ctrl D>, see appendix).

A transmission is only accepted if the sequence <Ctrl E> address <Ctrl E> is used !

e.g. print date/time/text:

<Ctrl E> address <Ctrl E> <Ctrl ^> <CR> characters...
<CR> <Ctrl D>

7.3. Handshake messages Serial interface

RTS / DTR

These lines indicate the printer status to the sender; DTR (device is on) is rather insignificant and is in general not used.

RTS high (+8 V) indicates: printer is ready to receive.

RTS low (-7 V) indicates: printer is not ready to receive.

The reasons for printer not being ready could be:

- Out of paper
- Print interval running
- Buffer is full
- Change menu

RTS / DTR are only used by the RS 232 C interface and can be used for Interface I and II.

Print interval (serial)

During the preset wait delay the interface is **not ready to** receive. After expiry of the wait delay the RTS signal (or XON) becomes active again and requests the subsequent transmission.

The next interval begins upon receiving of <CR> or <CR + LF>. <LF> on its own is not accepted.

XON / XOFF

The report functions „Printer read/not ready“ are handled by this protocol if no handshake lines are connected (RS 232 C, RS 422 or RS 485).

This function only applies to the E version, Interface II.

XON is transmitted if the IPP 144-40 GE is ready to receive.

XOFF is transmitted if the IPP 144-40 GE is not ready to receive (see above).

Note:

If the IPP 144-40 GE is not ready to receive, it transmits this character just once, not continuously.

No adjustments have to be made, this protocol always runs parallel to the hardware handshake.

Improved handshaking for pre-stored texts

After receiving the control command <CR> the printer now sets RTS at „BUSY“ or the signal XOFF is transmitted.

When the printing of pre-stored text is complete, RTS is reset or the signal XON is transmitted.

This handshake can be used to control the data transmission and prevent rapid text calls being lost or overwritten.

Note:

Without Handshake the following can occur, if the text calls are sent in too quickly:

Data input:

<Ctrl C> 1 <CR> <Ctrl C> 2 <CR> <Ctrl C> 3 <CR>

Actual Print-out:

Machine No. 3
2
3

pre-stored Text No. 1
just „2“ printed, Text No. 2 missing
just „3“ printed, Text No. 3 missing

With Handshake, provided RTS (or XON/XOFF protocol) is used to control the data transmitter:

Data input:

<Ctrl C> 1 <CR> <Ctrl C> 2 <CR> <Ctrl C> 3 <CR>

Actual Print-out:

Machine No. 3	pre-stored Text No. 1
Automatic mode	pre-stored Text No. 2
Status NORMAL	pre-stored Text No. 3

7.4. Version E (IPP 144 - 40 GE)

7.4.1. Text entry

Text can only be entered via Interface II.

The maximum text length is 40 characters. If the text length exceeds 40 characters, only the first 40 characters are saved.

Text will be input via Windows programming software. There is a special task for inputting, adding, overwriting and deleting texts. The text number must be two-digit.

You must set the following printer parameters:

Baudrate:	9600
Data format:	8
Parity:	NO PARITY
Interface:	SERIAL

For details of the Input task see the Windows programming software manual.

Reserving space for measured variables

In order to be able to insert measured value (variables) into text afterwards, the location within the text must be marked using <Ctrl V>, which reserves 6 spaces into which any characters may be entered, since they are overwritten at a later time anyway; they are merely wildcards.

Example:

Entry:

TEMPERATURE <Ctrl V> XXXXX °C <CR>

<Ctrl> counts as one digit, so you only have to enter 5 wildcard characters.

The printout would look like this:

TEMPERATURE 263,45 °C.

Creating a text block

A text block is created by combining several texts.

A text block can be printed in a single call.

To achieve this, place the beginning and the end of the text in brackets at entry time. Use the control characters:

<Ctrl X>= opening bracket

<Ctrl Y>= closing bracket.

The texts within a text block
must have **continuous** numbers !

To delete text within a text block without creating a blank line, the text numbers following the deleted line must be decreased by 1 to move them forward.

This is not done automatically but has to be entered manually.

7.4.2. Text output

Calling via serial Interface

In order to print text, the printer must receive a transmission with the following format:

< Ctrl C > text number < CR >

The printer looks up the stored text related with that number and prints it.

If there is no such text, nothing is printed.

Important notes:

- <LF> on its own does not start the printing !
- Between several text calls in a row there has to be a gap of least 2 seconds to make sure no text is skipped during printing !
- Several text calls using <Ctrl C> and „normal“ transmissions must not be combined !
- Combination of text and Date / time (protocol) see chapter 6.4. !

To call a printer with an address:

<Ctrl E> Adr. <Ctrl E> <Ctrl C> Nr. <CR> <Ctrl D>

Precede the call with the address (see chapter 7.2.). Example for text entry are given in chapter 8.5.

8. Appendix

8.1. Menu program / complete selection

Basic version

```

SET INTERVAL      NO ?
                  YES ?

SET INTERVAL      00 h 00 min 00 sec
                  00 h 00 min _0 sec
                  00 h 0_ min 50 sec
                  00 h _4 min 50 sec
                  0_ h 34 min 50 sec
                  _2 h 34 min 50 sec
>>>              12 h 34 min 50 sec

SET MODE          ON LINE
                  OFF LINE
>>>              ON LINE
                  ON LINE

SET PRINT STRENGTH NO ?
                  YES ?
PRINT STRENGTH   LEVEL1
                  LEVEL1
                  LEVEL2
                  LEVEL3
>>>              LEVEL4
                  LEVEL4

SET BAUDRATE      NO ?
                  YES ?
BAUDRATE          19200
                  38400
                  110
                  150
                  300
                  600
                  1200
                  2400
                  4800
>>>              9600
                  9600

SET DATA FORMAT  NO ?
                  YES ?
DATAFORMAT        8
                  7
>>>              7

SET PARITY        NO ?
                  YES ?
PARITY            NO PARITY
                  PARITY
                  EVEN
                  ODD
                  MARK
>>>              SPACE
    
```

```

NO PARITY
>>>              NO PARITY
PRINTER ADDRESS  NO ?
                  YES ?
PRINTER ADDRESS  00
                  _0
                  10
                  20
                  30
                  00
                  0_
>>>              01
                  .
                  09
                  00
>>>              00

SET PRINT FORMAT  NO ?
                  YES ?
PRINT FORMAT      INVERSE
>>>              NORMAL
                  NORMAL

SET CHARACTER/LINE NO ?
                  YES ?
CHARACTER/LINE    48 CHARACTERS
                  48 CHARACTERS
                  40 CHARACTERS
                  24 CHARACTERS
                  20 CHARACTERS
>>>              20 CHARACTERS
CHARACTER SET     NO ?
                  YES ?
CHARACTER          ASCII
                  GERMAN
                  FRENCH
                  DANISH
                  NORWEGIAN
                  SPANISH
                  UK
                  CYRILLIC
>>>              ASCII
                  ASCII
SET INTERFACE     NO ?
                  YES ?
INTERFACE         SERIAL
                  SERIAL
                  USB - SERIAL IF 2
>>>              SERIAL
                  SERIAL

*** END ***
    
```

Version E

```
SET TIME NO ?
YES ?
SET TIME 15:57:26
_5:57:00
. .
. .
15:4_ :00
>>> 15:48:00
TO STORE TIME, PLEASE PRESS „ENTER“
TO SET TIME AGAIN, PRESS „SELECT“
SET CALENDAR NO ?
YES ?
SET CALENDAR 12.01.2003
_2.01.2003
1_ .01.2003
. .
. .
16.02.0_
>>> 16.02.2004
CHANGE TIME W<->S NO ?
YES ?
CHANGE TIME W<->S 14:07:14
W --> S (+1h)
S --> W (-1h)
>>> 15:07:14

PRINT DATE/TIME NO?
YES?
PRINT DATE/TIME CTRL “ ^ “
HEADLINE
HEADLINE
>>> HEADLINE
```

SET ACCORDING TO THE BASIC VERSION

```
SET INTERVAL
SET MODE
SET PRINT STRENGTH
SET BAUDRATE
SET DATAFORMAT
SET PARITY
PRINTER ADDRESS
SET PRINT FORMAT
SET CHARACTER/LINE
SET CHARACTER
SET INTERFACE
```

*** END ***

8.2. Character sets

Control character used for data transmission

General purpose characters

Character	HEX	Significance	Name
Ctrl D	04	End of transmission	EOT
Ctrl E	05	Set address	ENQ
Ctrl J	0A	Line feed	LF
Ctrl M	0D	Carriage return	CR
Ctrl Q	11	Ready to receive	XON
Ctrl S	13	Busy	XOFF

Additional characters used by the printer

Ctrl F	06	48 character / line
Ctrl R	12	24 character / line
Ctrl T	14	Inverted printing
Ctrl U	15	Normal printing
Ctrl W	17	transmit request: date / time
Ctrl ^	1E	Print: date / time in protocol
Ctrl C	03	Text call
Ctrl X	18	Start of text block
Ctrl Y	19	End of text block
Ctrl V	16	Reserve space for measure variable (6 digits)

Character set - various languages

The following HEX codes differ from the ASCII character set:

Hex-Code	23	24	40	5B	5C	5D	5E	60	7B	7C	7D	7E
ASCII	#	\$	@	[\]	^	`	{		}	~
German	#	\$	§	Ä	Ö	Ü	^	`	ä	ö	ü	ß
S / SF	#	⌘	É	Ä	Ö	À	Ü	é	ä	ö	à	ü
French	#	\$	à	°	ç	§	^	`	é	ù	è	…
Danish	#	\$	É	Æ	Ø	À	Ü	é	æ	ø	à	ü
Norwegian	#	⌘	É	Æ	Ø	À	Ü	é	æ	ø	à	ü
Spanish	#	\$	à	í	Ñ	¿	é	`	□	ñ	ó	ú
English	£	\$	@	[\]	^	`	{		}	~

The following character set is used:

	0	1	2	3	4	5	6	7	8	9	A	B	C	D	E	F
2		!	"	#	\$	%	&	'	()	*	+	,	-	.	/
3	0	1	2	3	4	5	6	7	8	9	:	;	<	=	>	?
4	@	A	B	C	D	E	F	G	H	I	J	K	L	M	N	O
5	P	Q	R	S	T	U	V	W	X	Y	Z	[\]	^	_
6	`	a	b	c	d	e	f	g	h	i	j	k	l	m	n	o
7	p	q	r	s	t	u	v	w	x	y	z	{		}	~	
8	€	ü	é	ã	ä	å	ç	ê	ë	è	ï	î	ï	ÿ	À	Á
9	É	æ	Æ	ô	ö	õ	û	ü	ÿ	ö	ü	ß	É	ß	À	Á
A	ã	î	ó	û	ñ	Ñ	â	ó	ç	®	¬	½	¼	í	α	»
B	⌘	⌘	⌘		†	À	Ã	Ä	©	¶		π	⌘	=	¥	¬
C	L	⊥	⊥	⊥	⊥	+	ä	Ä	ℒ	℞	⊥	π	⊥	=	⊥	⊘
D	δ	⊖	⊖	⊖	⊖	'	ï	ï	ℒ	℞	⊥	⊥	⊥	=	⊥	⊘
E	ö	⊖	⊖	⊖	⊖	μ	⊖	⊖	ℒ	℞	⊥	⊥	⊥	=	⊥	⊘
F	-	±	⊖	¼	¶	§	÷	·	°	°	°	°	°	°	°	°

Character set: ASCII and cyrillic

Table explanation:

1.Column = ASCII / 2. Column = cyrillic / 3. Column = Hexadecimal

		20	@	@	40		Ю	60
!	!	21	А	Ф	41	a	Ф	61
"	"	22	В	И	42	b	и	62
#	#	23	С	С	43	c	с	63
\$	\$	24	Д	В	44	d	в	64
%	%	25	Е	У	45	e	у	65
&	&	26	Ғ	А	46	f	а	66
/	ю	27	G	Ч	47	g	ч	67
((28	H	П	48	h	п	68
))	29	I	Ш	49	i	ш	69
*	ь	2A	J	О	4A	j	о	6A
+	+	2B	K	Л	4B	k	л	6B
,	,	2C	L	Д	4C	l	д	6C
-	-	2D	M	Ё	4D	m	ё	6D
.	.	2E	N	Т	4E	n	т	6E
/	/	2F	O	Ш	4F	o	щ	6F
0	0	30	P	З	50	p	э	70
1	1	31	Q	Й	51	q	й	71
2	2	32	R	К	52	r	к	72
3	3	33	S	Ы	53	s	ы	73
4	4	34	T	Е	54	t	е	74
5	5	35	U	Г	55	u	г	75
6	6	36	V	М	56	v	м	76
7	7	37	W	Ц	57	w	ч	77
8	8	38	X	Р	58	x	р	78
9	9	39	Y	Я	59	y	я	79
:	:	3A	Z	Н	5A	z	н	7A
;	;	3B	[Э	5B	{	э	7B
<	<	3C	\	Ж	5C	`	ж	7C
=	=	3D]	Х	5D	}	х	7D
>	>	3E	^		5E	~	ó	7E
?	Б	3F	_	ь	5F	■	■	7F

8.3. Details of printer control commands

8.3.1. Short view of control commands

Print character commands (Section 8.3.2.)

ESC - n Specifies/clears underline

GS ! n Specifies character size

Bitmap image commands (Section 8.3.3.)

ESC * m nL nH Specifies column bitmap image

ESC A* nL nH Specifies raster bitmap image

Line feed fommands (Section 8.3.4.)

ESC 2 Specifies initial line feed

ESC 3 n Specifies line feed

Barcode commands (Section 8.3.5.)

GS H n Selects print position of HRI character

GS h n Sets barcode height

GS w n Sets width of barcode

GS k m / GS k m n Prints barcode

Print position commands (Section 8.3.6.)

ESC \$ nL nH Specifies absolute position

8.3.2. Print character commands

**Specifies /
clears
underline**

Command: ESC - n

<< Code >>

0x1B , 0x2D, n ($0 \leq n \leq 2$, $48 \leq n \leq 49$, initial value n=0)

<< Function >>

Specifies or clears an underline

n	Function
0, 48	Clears underline
1, 49	Sets a 1-dot wide underline and specifies an underline

Specifies character size **Command: GS ! n**
 << Code >>
 0x1D , 0x21, n
 (initial value n=0, Value see table)

<< Function >>
 Specifies character size (vertical and horizontal magnification)

Bit	Function	Value	
		0	1
0	vertical magnification	see Table 2	
1			
4	Horizontal magnification	see Table 1	
5			

Table 1

Bit7	Bit6	Bit5	Bit4	Magnification
0	0	0	0	1(Std.)
0	0	0	1	2(horizontal)
0	0	1	1	4(horizontal)

Table 2

Bit3	Bit2	Bit1	Bit0	Magnification
0	0	0	0	1(Std.)
0	0	0	1	2(vertical)
0	0	1	1	4(vertical)

<< Details >>

This command is ignored if either a vertical or horizontal magnification is outside the definable range.

In the standard mode, the vertical direction refers to the direction of paper feed, and the horizontal direction the direction right to the direction of paper feed. If characters are 90-degree right or left are specified, the relationship of the vertical and horizontal directions is reversed.

If characters with different vertical magnifications are contained in the same line, they are aligned to the baseline.

8.3.3. Bitmap image commands

Prints column Command: ESC *m nL nH d1~ dk
bitmap image << Code >>

0x1B , 0x2A , m , nL , nH , d1~ dk

where: m=0, 32, $0 \leq nL \leq 255$, $0 \leq nH \leq 3$, $0 \leq d \leq 255$

<< Function >>

Specifies a bitmap image in mode m for the number of dots specified by nL and nH.

m	Mode	No. of vertical dots	No. of Data (K)
0	8-dot single density	8 dots	$nL+nH \times 256$
1	8-dot double density	8 dots	$nL+nH \times 256$
32	24-dot single density	24 dots	$(nL+nH \times 256) \times 3$
33	24-dot double density	24 dots	$(nL+nH \times 256) \times 3$

<< Details >>

Processes the data after nL as normal data if m is outside the definable range. nL and nH denote the number of horizontal dots of the bitmap image to be printed, which is $(nL+nH \times 256)$.

If bitmap image data exceeding the number of printable dots in a line is entered, the excess data is discarded. d denotes bitmap image data. The bit for the dot to be printed is „1“ and the bit the dot not to be printed is „0“. Returns to normal data processing after bitmap image processing.

Has no effect on print modes (underline, character size) excluding NORMAL.

Prints the entered bitmap image magnified three times in the vertical direction if m=0 or 1 (8-dot mode) is specified and two times in the horizontal direction if m=0 or 32 (single density mode) is specified.

The data format of a bitmap is as follows:

Bitmap-Data format

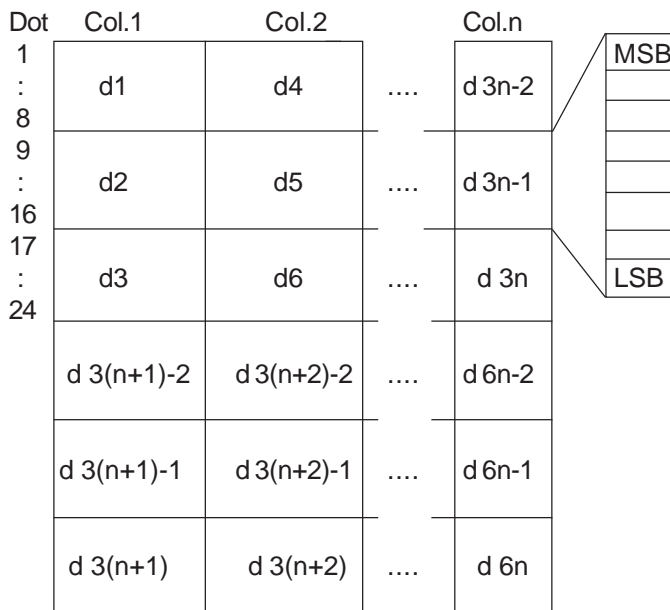

Prints raster bitmap image Command: **ESC A* nL nH d1~ dk**

<< Code >>

0x1B , 0x41 , 0x2A , nL , nH , d1~ dk

where: $0 \leq nL \leq 255$, $0 \leq nH \leq 255$, $0 \leq d \leq 255$

<< Function >>

Specifies the raster bitmap image specified with (nL + nH x 256) lines in the vertical direction.

<< Details >>

This command is effective only if this command is entered at the start position of a line in the standard mode. d refers to bitmap image data. The bit for the dot to be printed is „1“ and the bit for the dot not to be printed is „0“. The required number of image data per line is as follows depending on the number of heating elements in the head:

dots of heating element	192 dots	288 dots	384 dots	576 dots
No. data per line	24 bytes	36 bytes	48 bytes	72 bytes

The required total number of bitmap image data is $((nL + nH \times 256) \times \text{no. of data per line})$ bytes.
 The format of bitmap data for a printer with n heating elements in the head is as follows:

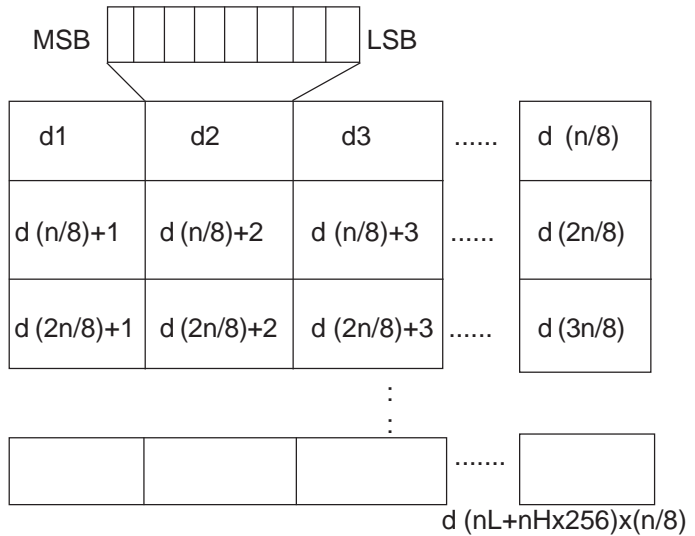

8.3.4. Line feed commands

**Sets initial
line feed**

Command: ESC 2

<< Code >>
 0x1B , 0x32

<< Function >>

Sets the amount of the initial line feed per line to 30 dots.

<< Details >>:

The amount of the initial line feed can be set separately for the standard mode.

**Sets
line feed**

Command: ESC 3n

<< Code >>

0x1B , 0x33 , n ($0 \leq n \leq 25$, initial value n=60)

<< Function >>

Sets the amount of line feed per line to n dot.

<< Details >>

Line feed can be set separately for the standard mode.

8.3.5. Barcode commands

**Selects
printing
position of
HRI character**

Command: GS H n

<< Code >>

0x1D , 0x48 , n ($0 \leq n \leq 3$, initial value n=0)

<< Function >>

Selects the print position of HRI characters when printing a barcode.

<< Details >>

HRI refers to Human Readable Interpretation.

n	PRINTING POSITION
0	Not printed (Default)
1	Above bar code
2	Under bar code
3	Above and under bar code

**Sets
barcode
height**

Command: GS h n

<< Code >>

0x1D , 0x68 , n ($1 \leq n \leq 255$, initial value n=128)

<< Function >>

Sets barcode height to n dots.

**Sets width
of barcode**

Command: GS w n

<< Code >>

0 x 1D , 0 x 77 , n ($2 \leq n \leq 6$, initial value n=3)

<< Function >>

Specifies barcode width.

**Prints
barcode**

Command: GS k n (Start) <data>NUL
<< Code >>
0x1D , 0x6B , n,(Start)<data> 00H (0≤n≤7)

<< Function >>
Selects a barcode system and prints barcodes.

In the case of GS k n:

n	START BYTE	BAR CODE TYPE
0	No Start-Byte	UPC-A
1	No Start-Byte	UPC-E
2	No Start-Byte	EAN 13
3	No Start-Byte	EAN 8
4	No Start-Byte	Code 39
5	No Start-Byte	Interleaved 2/5(ITF)
6	No Start-Byte	Codabar
7	135	Code 128A
7	136	Code 128B
7	137	Code 128 C

8.3.6. Print position commands

**Specifies
absolute
position**

Command: ESC \$ nL nH
<< Code >>
0x1B , 0x24, nL , nH (0≤nL≤255 , 0≤nH≤255)

<< Function >>
Specifies the next print start position as an absolute position based on the left margin position.
The next print start position is (nL + nH x 256) dots away from the left margin position.

<< Details >>
A print start position specified outside the print area is ignored.

8.4. Connection examples for Gossen Müller & Weigert instruments

8.4.1. Connection of the IPP 144-40 GE to the DPM-MF for the insertion of measured value into texts

For this configuration you must input and save the text as shown in section 7.4.1. of this manual.

The printer receives the measuring values via Interface I / RS 232 C (also possible via Interface II). To selected the text see section 7.4.2 in this manual. The relevant interface is the interface for which the parameters have to be set in the menu program. The recommended configuration is: 8 data bits, no parity, 1 stop bit, 9600 baud. With 7 bit, no parity, the sender must be set to 2 stop bits.

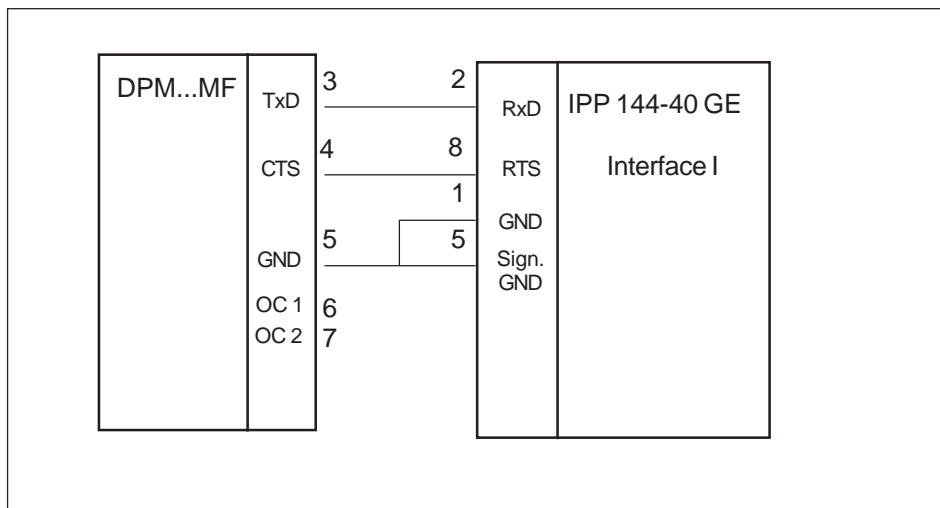

8.4.2. Connection of IPP 144 - 40 G with a DAA message display to print fault messages

Messages can be sent by all DAA type B and C versions. (The A version DAA are not capable of outputting data but only of displaying them since there is only one serial interface available which is used to receive data).

The connection of the printer is made via the Interface II (RS 232 C) of the DAA. The printout is normally triggered by a control device (e.g. a PLC) with a strobe signal (strobe T) via the terminal strip for control inputs (parallel interface) at the DAA.

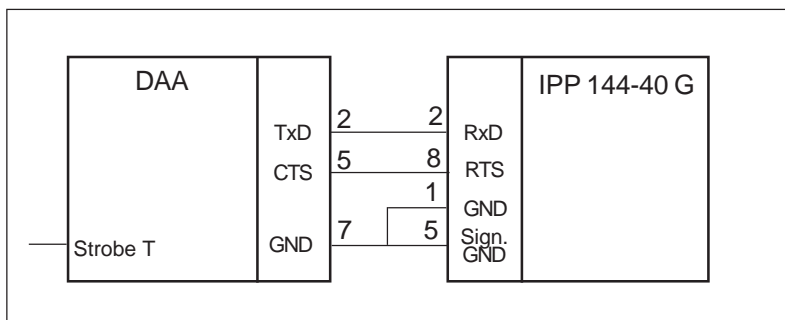

Interface RS - 232 C:

DAA 144 - 120 B: 9 pin D - SUB 9 pin D - SUB

DAA 288 - 120 B: 25 pin D - SUB

DAA 288 - 240 B, C: 25 pin D - SUB

The required connection cable is available as an accessory.

8.5. Examples for automatic text insert mode

Example 1:
Consignment
print-out, with
time & date,
marks and
weights

Data input:

10:15:33 15/10/03 <CR>1<CR> 123 <CR> 1 <CR> 1027<CR> 997 <CR> 30 <CR>

Actual Print-out:

10:15:33	15/10/2003
Product Ref:	123
Operator No:	1
Gross:	1027 kg
Nett:	997 kg
Tare:	30 kg

Pre-stored texts

(„T“ = spaces reserved for variable data)

1	TTTTT
2	Product Ref: TTTTTT
3	Operator No: TTTTTT
4	Gross: TTTTTT
5	Nett: TTTTTT
6	Tare: TTTTTT

Six blocks of data are inserted and printed in sequence.

Example 2:
Quality test
print-out, with
several
measured
value

In this example, the IPP144-40 GE automatically adds date & time from its own real-time clock using the „PRINT DATE / TIME-HEAD-LINE“ menu option. Four blocks of variable data are sent to the printer.

Data input: 115<CR> 33.7<CR> 62.8<CR> 228.7<CR>

Actual Print-out:

Pre-stored texts

13.10.03	13:49:52
Metrix Electronics Ltd.	
Rankine Road, Daneshill West	
GB-Basingstoke RG24 8PP	

Test Number:	115
--- TEST RESULTS ---	
Ambient Temp	33.7 °C
Burn-in Temp	62.8 °C
Nom. Supply	230 Vac
Actual	228.7 Vac

1	Metrix Electronics Ltd.
2	Rakine Road, Daneshill West
3	GB-Basingstoke RG24 8PP
4	-----
5	Test Number: TTTTTT
6	--- TEST RESULTS ---
7	Ambient Temp TTTTTT°C
8	Burn-in-Temp TTTTTT°C
9	Nom. Supply 230 Vac
10	Actual TTTTTTVac

The print-out is 10 texts - 4 with variable data inserted and 6 without.

Example 3:
A simple way
to print a
group of texts

This mode can be used to print a group of texts, triggered by a single <CR> input, even if no variable data is required to be inserted.

NOTE: Text No. 7 is only pre-programmed with a variable data field.

Data input: <CR>

Actual Printout:

Pre-stored texts

15.10.2003	10:34:53
Manufactured by::	

Metrix Electronics Ltd.	
Rankine Road, Daneshill West	
GB-Basingstoke RG24 8PP	

1	Manufactured by:
2	-----
3	Metrix Electronics Ltd.
4	Rankine Road, Daneshill West
5	GB-Basingstoke RG24 8PP
6	-----
7	TTTTTT

All the texts up to Text No. 6 (without variable fields) are printed. Text No. 7 (the first variable field) just prints a blank line. (If there was any variable data sent before the <CR> this would be inserted and printed here.) 51

II Paper reroll mechanism IPP - AW

1. General information

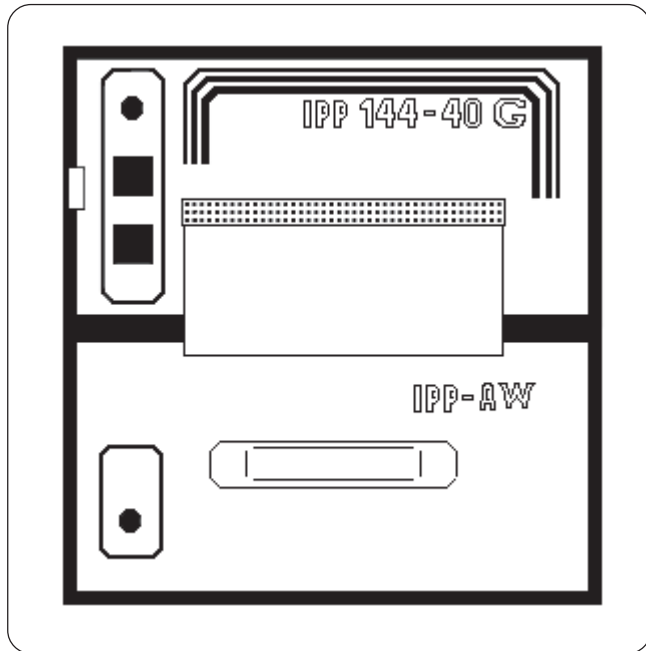

The IPP-AW is a paper reroll mechanism designed for use with the Thermal Graphics Printer IPP 144-40 G. It has been designed to match the printer in colour and style. It is preferably installed directly underneath the printer. The printed paper is automatically wound on a drum by a motor. A front panel draw allows easy paper handling.

The paper reroll mechanism is a DIN size panel mounting unit. It is supplied with power and controlled via connector cable which comes with the unit and which is connected to connector 12 of the IPP 144-40 G (see chapter 3.). An LED indicates the ready status. Depending on the distance between the two devices at least the last 9 lines printed remain visible.

Design

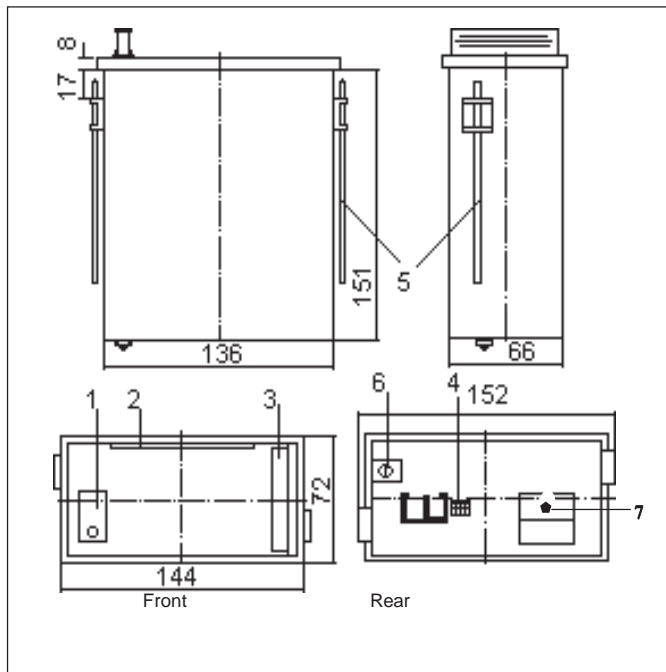

- | | | | |
|---|--|---|--|
| 1 | Status indicator | 2 | Opening for paper feed |
| 3 | Handle | 4 | Connector for connection cable IPP 144-40; |
| 5 | Mounting screws | | (pin connections: Motor control, +5V, open, GND) |
| 6 | Protective conductor connection (must be connected to ground) | | |
| 7 | Brightness LED | | |

Installation

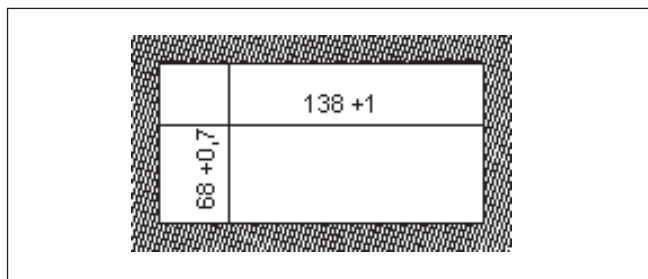

The paper reroll mechanism is inserted into the DIN size panel cutout from the front side and is clamped against the rear of the switchboard using the mounting screws. The switchboard thickness must not exceed 12 mm.



Make sure that the unit is properly mounted before connection and power on.

2. Technical data

Winding	Motor with friction clutch, electronic lag 3 sec	
	Paper width:	max. 80 mm
	Paper length:	max. 15 m
Ambient conditions	Store temperature range:	-20 °C to +80 °C
	Operating temperature range:	0 °C to +70 °C
	Climate:	relative humidity < 80 % up to 31 °C
Standards	Protection type housing:	IP 50 acc. to EN 60528/VDE 0470
	Mech.strength:	To IEC 1010
	Safety:	EN 61010-1:2001 CATIII >150V ≤ 300V Pollution degree 2
	EMC Susceptibility:	DIN EN 610004-1 to EN 610004-4
	Emission:	DIN EN 50081-2 Class B
Miscellaneous	Dimensions (WxHxD):	144 x 72 x 159 mm
Connection	Connector:	MASCON female multi point connector, 4 pin keyed
	Connector cable:	AWG 26, approx. 100mm
	Power supply:	by IPP (5 V DC)
CE		

Maintenance friction clutch The torque of the friction clutch has been factory adjusted and should not require adjustment.

The winding force of the motor can be adjusted by slightly rotating the screw accessible through the left hand side hole in the body:

- **less** = turn left
- **more** = turn right

3. Operation

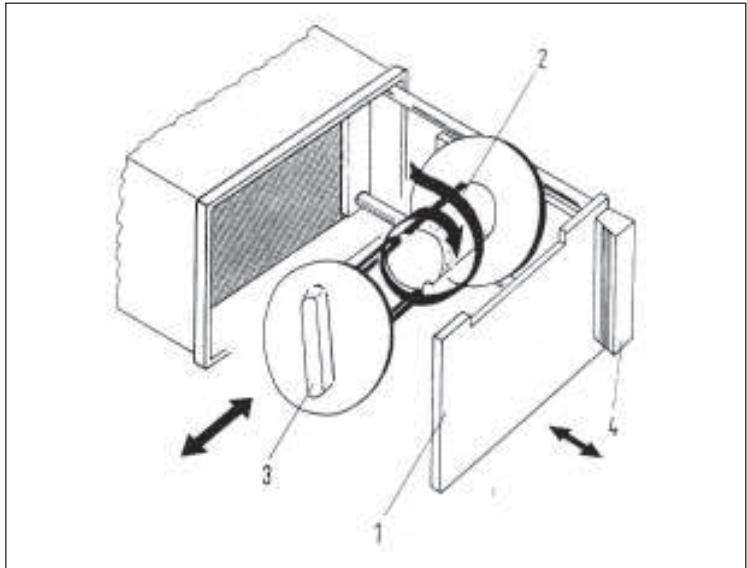

Removing the paper

- ➔ Use the handle (4) to pull out the front panel (1).
- ➔ Remove the holder (3) with the paper from roll body, rotate the notch of the holder as show in the diagram.
- ➔ Remove the paper drum from the holder.

Inserting the paper

- ➔ Wind the paper once around the drum body (2) in the direction indicated by the arrow.
- ➔ Plug in the holder (3) in such a way that the pins fit into the notches of the body.
- ➔ Close the front panel.
- ➔ Briefly press the „LINE FEED“ key at the IPP 144 - 40 G until the paper has been straightened out.

III Accessories

- ◆ Paper reroll mechanism IPP - AW
(incl. connection cable).

- ◆ Protection cover for use of IPP 144-40 G with IPP-AW,
Protection class: IP 64.
Dimensions: 155 x 155 [mm].
Material: Plexiglas and
Santoprene 101-80 rubber

- ◆ Connection cable for serial data transmission
to the following devices:
 - IBM-PC XT and AT or compatibles
 - Siemens PG 685 (V 24)
 - Siemens PG 675 / 685 (printer interface)
 - Siemens GP270 / TP270 / MP370 TOUCH (RS232C)
(printer interface)
 - Message displays:
DAA 144-120B / 288-120B / 288-240B, C
others on request.

 - Connection cable for USB-interface:
USB-A connector - USB-B connector

- ◆ Windows programming software for IPP 144-40 GE version (CD-R)

Safety instructions (EN 61010-1)

In order to preclude any danger to the operator, the following instructions should be followed:

- a) In case any damage or malfunction is detected, take the unit out of operation without delay.
- b) Before disassembling the unit, disconnect all inputs / outputs and the supply voltage. When mounting the unit and the connections, make sure all live components are protected from being touched directly.
- c) Comply with the usual regulations and safety provisions for low and high current systems, in particular country-specific safety provisions (e.g. VDE 0100).
- d) The maximum admissible potential existing between the pin groups as well as to the external protective conductor must not be exceeded. Refer to the unit's identification label.
- e) When connecting the unit to other devices (e.g. PCs), the connection must be carefully planned. Internal connections in external units (e.g. GND connected to protective earth) may cause excessive voltage potential.
- f) This device must be grounded! For low voltage $12V_{DC}$ and $24V_{DC}$ systems use screened cable. Units with a.c. supply voltage must be connected the protective conductor.
- g) Make sure that the unit is property mounted before connection and power on !

In order to preclude any damage to the unit, the following items must be taken into account:

The maximum admissible potential between the pin groups must not be exceeded.
This applies in particular to high voltage tests.



Refer to the instruction manual !



Warning: Hazardous live voltage !

WARNING:

There is always hazardous voltage present in certain parts during the operation of electrical equipment. Non-observance of the safety instructions can result in severe personal injury or damage to property. Only qualified personnel should work on this equipment. The successful and safe operation of this equipment is dependant on proper transport, storage, set-up, installation and careful operation and maintenance.

QUALIFIED PERSONNEL

Are personnel who are familiar with the set-up, installation, commissioning and operation of the product and have the qualifications corresponding to their activities, e.g.:

- Are trained and authorised to energise, de-energise, clear, ground and tag circuits and equipment / systems in accordance with established safety standards.
- Are trained in the proper care and use of protective equipment in accordance with established safety practices.
- Are trained in first aid.

Safety according to EN 61010-1, VDE 0411

CAT III > 150 V ≤ 300 V

Pollution degree : 2; indoor use; altitude <2000 m; relative humidity <80 % up to 31 °C;
Temperature: 5°C to 40 °C;

Note:

Exclusive agent for UK & Ireland:

Metrix Electronics Limited

Electronic Instrument Solutions for Industry
Minchens Court, Minchens Lane, Bramley,
Hampshire RG26 5BH, U.K.

Tel. +44 (0)845 03 43 234

Fax: +44 (0)845 03 43 233

E-mail: sales@metrix-electronics.com

Web: **www.metrix-electronics.com**

GOSSEN Müller & Weigert

ZN der General Elektronik GmbH

Kleinreuther Weg 88

D-90408 Nürnberg

Tel.: +49(0)911/3502-0 Fax: +49(0)911/3502-307

E-mail: info@g-mw.de Internet: www.g-mw.de

